

---

# *VISTA-20HWSE*

---

2-PARTITIONED  
SECURITY SYSTEM

## **INSTALLATION INSTRUCTIONS**

**® ADEMCO**

Principal changes between the VISTA-20HWSE and the former VISTA-20HW are indicated by margin lines.

# RECOMMENDATIONS FOR PROPER PROTECTION

The Following Recommendations For The Location Of Fire And Burglary Detection Devices Help Provide Proper Coverage For The Protected Premises.

## Recommendations For Smoke And Heat Detectors

With regard to the number and placement of smoke/heat detectors, we subscribe to the recommendations contained in the National Fire Protection Association's (NFPA) Standard #72 noted below.

Early warning fire detection is best achieved by the installation of fire detection equipment in all rooms and areas of the household as follows: For minimum protection a smoke detector should be installed outside of each separate sleeping area, and on each additional floor of a multi-floor family living unit, including basements. The installation of smoke detectors in kitchens, attics (finished or unfinished), or in garages is not normally recommended.

For additional protection the NFPA recommends that you install heat or smoke detectors in the living room, dining room, bedroom(s), kitchen, hallway(s), attic, furnace room, utility and storage rooms, basements and attached garages.

In addition, we recommend the following:

- Install a smoke detector inside every bedroom where a smoker sleeps.
- Install a smoke detector inside every bedroom where someone sleeps with the door partly or completely closed. Smoke could be blocked by the closed door. Also, an alarm in the hallway outside may not wake up the sleeper if the door is closed.
- Install a smoke detector inside bedrooms where electrical appliances (such as portable heaters, air conditioners or humidifiers) are used.
- Install a smoke detector at both ends of a hallway if the hallway is more than 40 feet (12 meters) long.
- Install smoke detectors in any room where an alarm control is located, or in any room where alarm control connections to an AC source or phone lines are made. If detectors are not so located, a fire within the room could prevent the control from reporting a fire or an intrusion.

**THIS CONTROL COMPLIES WITH NFPA REQUIREMENTS FOR TEMPORAL PULSE SOUNDING OF FIRE NOTIFICATION APPLIANCES.**

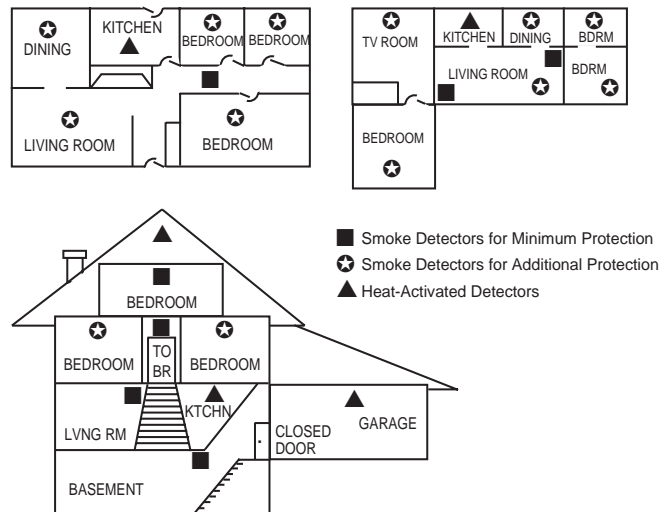

## Recommendations For Proper Intrusion Protection

For proper intrusion coverage, sensors should be located at every possible point of entry to a home or commercial premises. This would include any skylights that may be present, and the upper windows in a multi-level building.

In addition, we recommend that radio backup be used in a security system so that alarm signals can still be sent to the alarm monitoring station in the event that the telephone lines are out of order (alarm signals are normally sent over the phone lines, if connected to an alarm monitoring station).

# TABLE OF CONTENTS

<b>Section 1.</b>	<b>GENERAL DESCRIPTION</b> .....	7
<b>Section 2.</b>	<b>INSTALLING THE CONTROL</b> .....	10
	Mounting the Cabinet.....	10
	Installing the Lock (if used) .....	10
	Mounting the Control's Circuit Board in the Cabinet .....	10
	Standard Phone Line Connections.....	11
	Wiring the AC Transformer .....	11
	Installing the Back-Up Battery.....	12
	Earth Ground Connections .....	12
<b>Section 3.</b>	<b>INSTALLING REMOTE KEYPADS</b> .....	13
	Keypads That May Be Used .....	13
	Wiring The Keypads .....	13
	Mounting The Keypads.....	14
	Using A Supplementary Power Supply To Power Additional Keypads .....	14
	Preliminary Check-Out Procedure.....	15
<b>Section 4.</b>	<b>BASIC HARD-WIRED ZONES 1-8</b> .....	16
	Installing the Hard-Wired Zones .....	16
	Common Characteristics For Zones 1-8.....	16
	Wiring Burglary and Panic Devices to Zones 1-8.....	16
	Wiring 2-Wire Smoke Detectors to Zone 1 .....	16
	“Verify” Operation of 2-Wire Smoke Detectors in Zone 1 .....	16
	Turning Off Fire Alarm Sounding .....	17
	Wiring 4-Wire Smoke/Combustion Detectors on Zones 2-7.....	17
	Wiring 2-Wire Latching Type Glass Break Detectors on Zone 8 .....	18
	Check-Out Procedure for Hard-Wired Zones .....	19
<b>Section 5.</b>	<b>WIRED ZONE EXPANSION (4219, 4229)</b> .....	20
	Installing Zone Expansion Units .....	20
	Connections and Set-Up.....	20
	Check-Out Procedure for Wired Expansion Zones.....	21
<b>Section 6</b>	<b>RELAY OUTPUTS &amp; POWERLINE CARRIER DEVICES</b> .....	22
	Relay/Powerline Carrier Device Basics .....	22
	Nos. 4204 And 4229 Output Relay Modules .....	22
	4204/4229 Setup .....	22
	Powerline Carrier Devices.....	23
	Wiring Connections .....	24
<b>Section 7.</b>	<b>4285 PHONE MODULE</b> .....	25
	Installing the Phone Module .....	25
	General Information .....	25
	Mounting The Phone Module .....	25
	Phone Module Wiring.....	26
	Caller ID Units .....	26
	Checking the Operation of the 4285 Phone Module.....	28
<b>Section 8.</b>	<b>EXTERNAL SOUNDERS</b> .....	29
	Compatible Sounders.....	29
	Sounder Connections .....	30
	Testing the Sounder.....	30
<b>Section 9.</b>	<b>LONG RANGE RADIO</b> .....	31
	General Information .....	31
	Connection.....	31
<b>Section 10.</b>	<b>AUDIO ALARM VERIFICATION (AAV) UNIT</b> .....	32
	General Information .....	32
	Wiring Connections.....	32

<b>Section 11. FINAL POWER UP .....</b>	<b>34</b>
Earth Ground Connections .....	34
Connecting the Back-Up Battery .....	34
Calculating the Battery Size Needed .....	34
Making the Battery Connections .....	35
Auxiliary Device Current Draw Worksheet .....	35
<b>Section 12. MECHANICS OF PROGRAMMING .....</b>	<b>36</b>
General Programming Information .....	36
Entering Program Mode .....	36
Programming a Data Field .....	36
Reviewing a Data Field/Erasing an Entry in a Data Field .....	37
Interactive Mode Programming (*56, *80, and *82) .....	37
Loading Factory Defaults .....	37
Programming System Setup Fields .....	37
Exiting the Programming Mode .....	37
<b>Section 13. ZONE RESPONSE TYPE DEFINITIONS .....</b>	<b>38</b>
<b>Section 14. DATA FIELD DESCRIPTIONS .....</b>	<b>40</b>
<b>Section 15. ZONE PROGRAMMING (*56 Menu Mode) .....</b>	<b>49</b>
<b>Section 16. OUTPUT DEVICES (*80 Menu Mode) .....</b>	<b>51</b>
<b>Section 17. ZONE LISTS (*81 Menu Mode) .....</b>	<b>55</b>
<b>Section 18. ALPHA DESCRIPTION PROGRAMMING (*82 Menu Mode) .....</b>	<b>56</b>
Zone Descriptors .....	56
Programming Zone Descriptors (in program Menu Mode *82) .....	56
Adding Custom Words .....	59
Alpha Vocabulary List (For Entering Zone Descriptors) .....	60
Character (ASCII) Chart .....	60
<b>Section 19. REMOTE PROGRAMMING AND CONTROL (DOWNLOADING) .....</b>	<b>61</b>
General Information .....	61
Equipment Required .....	61
Initial Download .....	61
Remote Programming Information .....	62
Remote Programming Advisory Notes .....	62
<b>Section 20. SYSTEM COMMUNICATION .....</b>	<b>63</b>
Report Code Formats .....	63
Table of Contact ID Codes .....	65

<b>Section 21. SYSTEM OPERATION</b> .....	66
Security Codes.....	66
Keypad Functions .....	67
Trouble Conditions .....	69
<b>Section 22. TESTING THE SYSTEM</b> .....	70
Test Procedure .....	70
To the Installer .....	70
<b>Section 23. TROUBLESHOOTING GUIDE</b> .....	71
Contacting Technical Support In The Event Of Problems .....	72
REGULATORY AGENCY STATEMENTS .....	73
<b>Section 24. SPECIFICATIONS &amp; ACCESSORIES</b> .....	74
Specifications .....	74
Accessories (Compatible Devices) .....	76
<b>Index</b> .....	77
<b>Limitations Of This Alarm System</b> .....	82
<b>Summary Of Connections</b> .....	83
<b>Limited Warranty</b> .....	84
<b>Programming Form</b> .....	Insert

## LIST OF FIGURES

Figure 1. Installing the Cabinet Lock.....	10
Figure 2. Mounting The PC Board .....	10
Figure 3. NOT USED	
Figure 4. Telephone Line Connections .....	11
Figure 5. Connection of 4300 Transformer to the Control Board .....	12
Figure 6. Keypad Connections to the Control Board .....	14
Figure 7. Using a Supplementary Power Supply.....	15
Figure 8. 2-Wire Smoke Detector Connected to Zone 1 .....	17
Figure 9. 4-Wire Smoke Detector Connections (Zones 2-7) .....	17
Figure 10. Glass Break Detector Connections to Zone 8 .....	18
Figure 11. Wiring Connection, 4219 & 4229 (4229 shown) .....	20
Figure 12. NOT USED	
Figure 13. 4229 Connections To Control .....	23
Figure 14. 4204 Connections To Control .....	23
Figure 15. 4300 Transformer Wiring Connections .....	24
Figure 16. 4285 Phone Module Wiring Connections.....	27
Figure 17. Typical Sounder Wiring.....	30
Figure 18. Long Range Radio Connections.....	31
Figure 19. NOT USED	
Figure 20. Connection of AAV Unit When Not Using a 4285 Phone Module...	33
Figure 21. Connection of AAV Unit When Also Using a 4285 Phone Module .	33
Figure 22. VISTA-20HWSE Summary of Connections.....	Inside Back Cover



---

# CONVENTIONS USED IN THIS MANUAL

---

MAIN SECTION TITLES ARE SHOWN IN REVERSE TYPE

Before you begin using this manual, it is important that you understand the meaning of the following symbols (icons).

	These notes include specific information which must be followed if you are installing this system for a UL Listed application.
	These notes include information that you should be aware of before continuing with the installation, and which, if not observed, could result in operational difficulties.
	This symbol indicates a critical note that could seriously affect the operation of the system, or could cause damage to the system. Please read each warning carefully. This symbol also denotes warnings about physical harm to the installer.

Enter Zn Num. (00 = Quit)                      01
--

Many system options are programmed in an interactive mode by responding to Alpha keypad display prompts. These prompts are shown in a double-line box.

**\*00**

When programming the system, data fields are indicated by a "star" (\*) followed by the data field number.

**PRODUCT MODEL NUMBERS:** Unless noted otherwise, references to specific model numbers represent Ademco products.

# Section 1. GENERAL DESCRIPTION

The VISTA-20HWSE is a 2-partition control that supports up to 16 zones, using basic hard-wired and wired expansion zones, plus 3 keypad activated zones.

## Basic Hardwired Zones

Provides 8 basic hardwired zones having the following characteristics:

- EOLR supervision supporting N.O. or N.C. sensors
- Programmable response time (10, 350, or 700 milliseconds)
- Individually assignable to either partition
- Up to sixteen 2-wire smoke detectors on zone 1
- 4-wire smoke or heat detectors on zones 2 through 7 (as many as can be powered from AUX power on the control)
- Up to fifty 2-wire latching type glassbreak detectors on zone 8 with auto reset

## Optional Expansion Zones (up to 8)

Supports up to 8 additional wired zones using a 4219 expansion module or 4229 expansion/relay module, each zone having the following characteristics:

- EOLR supervision supporting N.O. or N.C. sensors
- 300–500 msec normal response with an option for fast (10–15 msec) response on loop A (first expansion zone)

## Two Partitions

- Provides the ability to control two separate areas independently, each area functioning as if it had its own separate control
- Zones assignable to either partition 1 or 2
- Relay and Powerline Carrier device outputs assignable to either partition 1 or 2, or to both partitions
- Certain system options, such as Entry/Exit delay and Subscriber Account number, programmed independently for each partition
- Common Zone option allows either partition to arm, while leaving a common area (ex. lobby or foyer) disarmed for access into the other partition. Refer to the ZONE LISTS section for details on programming a common zone.

**UL**

In UL installations, the system may be configured as a single partition only.

## Remote Keypads

Up to 4 of any of the following keypads may be used in each partition:

Fixed-Word Keypads: 4127\*, 4137AD, 6127\*, 6137, and 6128.

\* These keypads cannot be used if the 4285 Phone Module is being used.

Alpha Keypads: 5137AD, 6139 (2-line alphanumeric displays)

6138 (1-line alphanumeric display).



For programming from a keypad, a 5137AD or 6139 2-line Alpha keypad must be connected to partition 1 (but need not stay in the system).

## Security Codes

- One installer code for entire system (user 1)
- One Master code for each partition (user 2)
- 12 secondary user codes for each partition (users 3–14)
- One baby-sitter code for each partition (user 15)
- One duress code for each partition (user 16)

	<p><b>Baby-sitter Code:</b> A special code that can only be used to disarm the system if that particular code was used to arm it.</p> <p><b>Duress Code:</b> An emergency code which, when entered by <i>any</i> user to disarm or arm the system, will send a silent duress message to the central station.</p>
---	--

## Keypad Panic Keys

- Up to 3 programmable panic key functions are provided.
- Designated as Zones 95, 96, 99
- Reported separately by partition, distinguished by subscriber ID number

## Zone Monitor Feature

- The control will sense a high resistance in the loops on hard-wired zones 2–8 if it is present, and will display a trouble message (rather than an alarm) for the affected zone when the system is in the disarmed mode. This feature also prevents the system from being armed while this high resistance condition exists.

## Exit Error False Alarm Prevention Feature

- Enables the system to determine the difference between an actual alarm and an alarm caused by leaving an Entry/Exit or Interior zone open after the exit delay expires. If not disarmed in time, an alarm will sound and an “Exit Error” report sent to the central station.
- An Exit Alarm condition will also occur if an Entry/Exit or Interior zone re-opens within 2 minutes after the end of an exit delay.

## Optional Output Relays and Powerline Carrier Devices (X-10 type)

- Up to 4 relays using one 4204 Relay Module
- Up to 2 relays using one 4229 Zone/Relay Module
- Up to 8 Powerline Carrier devices (you must subtract the number of relay outputs actually used by the 4204 or 4229 modules, if used)
- Actions programmable to respond to zone activity or manual keypad entries

	Powerline Carrier devices require the use of optional 4300 transformer module instead of the supplied 1321 AC transformer.
---	--

## Optional Phone Module

- Supports the Ademco 4285 Phone Module on Partition 1 only.
- Provides access to the system via on premises or off-premises phones for arming, disarming, etc., plus control of relay outputs and Powerline Carrier devices.

## Paging Feature

- If programmed, the paging feature allows certain system conditions to be reported to a pager, where a 10-digit code indicates the type of condition that has occurred.

## Audio Alarm Verification Option

- Provides a programmable Audio Alarm Verification (AAV) option which can be used in conjunction with an output relay to permit voice dialog between an operator at the central station and a person at the premises.
- Requires the use of optional AAV unit, such as Eagle model 1241.

<b>UL</b>	The AAV option may not be used in UL installations.
-----------	---

### Optional Long Range Radio

- Allows all messages that have been programmed to go to the primary telephone number to be reported additionally to a 7720PLUS or 7820 radio. Check availability of these models.

### Built-in Telephone Line Monitoring Option

- The telephone line voltage can be monitored to supervise the phone line connection. **The panel must be connected to a proper earth ground or you will get a false line cut indication if this feature is enabled.**
- The loss of the line can optionally cause a local display, or a display and trouble sound.

### Event Logging

- Event Logging feature keeps a record of selected events in a history log (up to 48 events). All control and readout from the log is done via Ademco V-Link software **only**.

### Alarm Output

- Provides a 12VDC, 2 AMP output that can drive the compatible sounders listed in the EXTERNAL SOUNDERS section (assumes a fully charged battery is connected).
- Steady output for Burglary/Panic, or temporal pulse output (3 pulses – pause – 3 pulses – pause – 3 pulses. . .) for Fire
- Uses current limiting circuitry for protection

### Auxiliary Power Output

- Provides 12VDC, 600 mA maximum. Uses current limiting circuitry for protection.
- This output interrupts for smoke detector reset if 4-wire smoke detectors are used.

### Programming

- Programmed options are stored in electrically erasable, non-volatile EEROM memory (information can be reprogrammed at any time and will not be lost in the event of a power loss).
- The system can be uploaded, downloaded, or controlled via an IBM compatible computer, V-Link software and a HAYES modem specified by Ademco.

Keypad programming consists of:

- Data field programming
- Interactive (menu) mode programming



For programming from a keypad, a 5137AD or 6139 2-line Alpha keypad must be connected to partition 1 (but need not necessarily stay in the system).

### Communication Formats Supported

- Ademco Low Speed (Standard or Expanded)
- SESCOA/Radionics (Standard or Expanded)
- Ademco Express
- Ademco Contact ID

### Zone Descriptors

You can assign Alpha descriptors to all zones (useful only when using Alpha keypads and/or the 4285 Phone Module).

### AC Power Supply

Uses 1321, 110VAC plug-in transformer with 16.5VAC 25VA output, unless Powerline Carrier devices (ex. X-10 type) are used, in which case a 4300 transformer module must be used.

### Back-Up Battery

- Rechargeable (Gel type) 12VDC, 4AH minimum.

## Section 2. INSTALLING THE CONTROL

This section provides instructions for mounting the control cabinet, and installing the cabinet lock (if used). Also included in this section are instructions for the following:

- Installing the main PC board
- Standard phone line connections
- Installing the back-up battery in the cabinet
- Connecting the AC transformer
- Making earth ground connections

### Mounting the Cabinet

Mount the control cabinet to a sturdy wall using fasteners or anchors (not supplied), in a clean, dry area which is not readily accessible to the general public. Four mounting holes are provided at the back of the cabinet.

### Installing the Lock (if used)

Use an Ademco No. N6277 Cam Lock and No. N6277-1 Push-On Clip (Retainer Clip).

**Note:** The cabinet can be closed and secured without a lock by using 2 screws in the cover's edge.

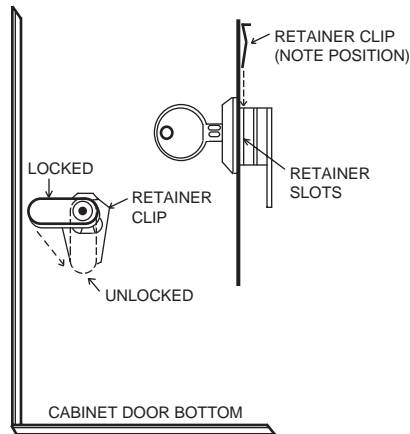

1. Remove the cabinet door. It is easily removable for servicing and is easily re-installed.
2. Remove the lock knockout from the control cabinet door. Insert the key into the lock. Position the lock in the hole making certain that the latch will make contact with the latch bracket when the door is closed.
3. Hold the lock steady, and insert the retainer clip into the retainer slots. Position the clip as illustrated in order to permit easy removal.

Figure 1. Installing The Cabinet Lock



Before installing the cabinet's contents, remove the metal cabinet knock-outs required for wiring entry. Do not attempt to remove the knockouts after the circuit board has been installed.

### Mounting The Control's Circuit Board in The Cabinet (Fig. 2)

1. Hang two short Black mounting clips (provided) on the raised cabinet tabs (see Detail B in Fig. 2).
2. Insert the top of the circuit board into the slots at the top of the cabinet. Make sure that the board rests on the correct row (see Detail A).
3. Swing the base of the board into the mounting clips and secure the board to the cabinet with the accompanying screws (see Detail B in Fig. 2).

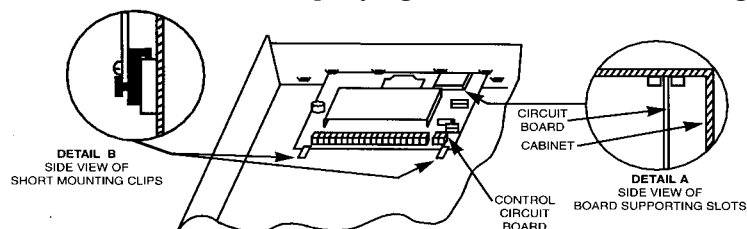

Figure 2. Mounting The PC Board

## Standard Phone Line Connections



The wiring connections shown here are not applicable if the 4285 Phone Module is used. Refer to the 4285 Phone Module section for information regarding phone line connections, which are different than those shown here.

Incoming phone line and handset wiring is connected to the main terminal block (via a RJ31X jack) as follows (also see Figure 4):

- Term. 21: Local Handset (TIP – Brown\*)
- Term. 22: Local Handset (RING – Gray\*)
- Term. 23: Incoming Phone Line (TIP – Green\*)
- Term. 24: Incoming Phone Line (RING – Red\*)

\* Colors of wires in Direct Connect Cord.

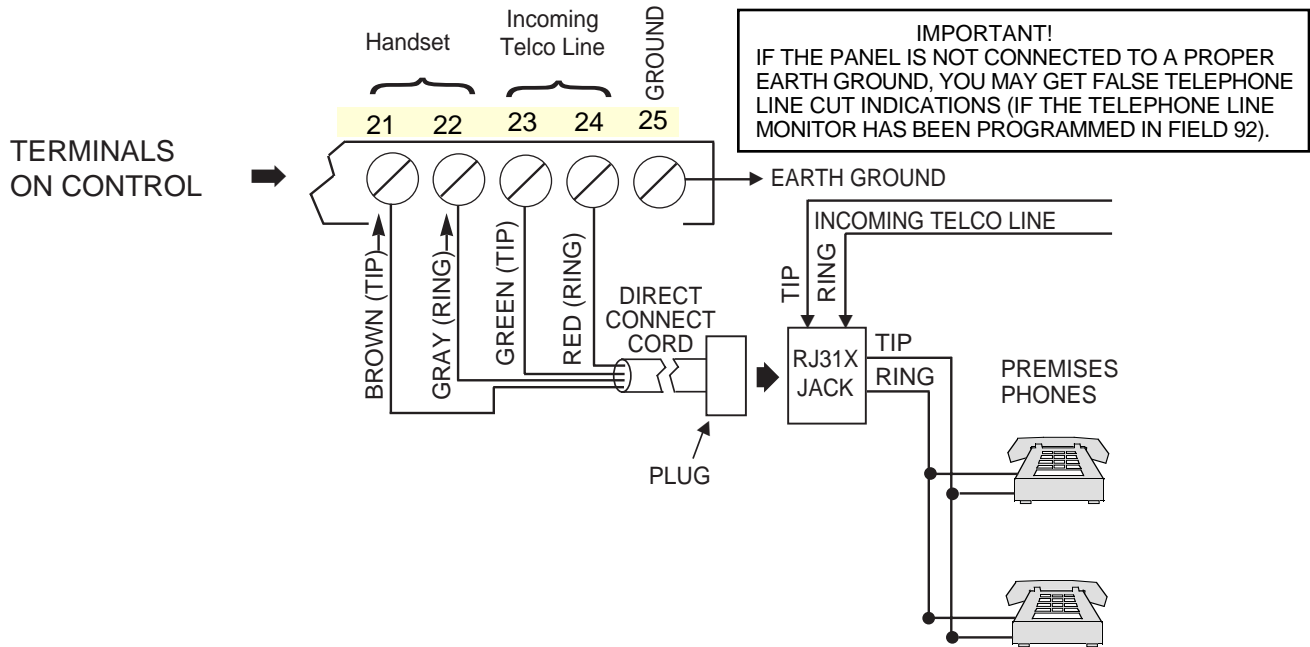

Figure 4. Telephone Line Connections

### Wiring The AC Transformer

**1321** Wire the 1321 transformer to terminals 1 and 2 on the control board. See wiring table below for wire gauge to use.

Caution must be taken when wiring the transformer to the control panel to guard against blowing the fuse inside the transformer (the fuse is non-replaceable).

**4300** If you are going to use a 4300 transformer interface (required if Powerline Carrier devices are going to be used), connect the 4300 transformer's terminals as follows:

- a. Terminals 1, 3 (AC), and 2 (Ground) to control board terminals 1, 2, and 25, respectively (see Figure 5). See table below for wire gauge to use.

WIRING TABLE	
Distance of Transformer From the Control Panel	Wire Gauge To Use
Up to 50 feet	# 20
50-100 feet	# 18
100-250 feet	# 16



Wiring to the AC Transformer must not exceed 250 feet using 16 gauge wire. The voltage reading between terminals 1 and 2 of the control must not fall below 16.5VAC or an "AC LOSS" message will be displayed.

Do not plug the transformer into the AC outlet until you are instructed to do so later in the manual.

- b. Wire the other three terminals (Sync, Data, Com) on the 4300 transformer. Wires from these terminals must be connected to a 9-pin connector on the control board (using a 4142TR cable supplied with the 4300 transformer), as shown in Figure 5. These particular wires can be 24 gauge or larger, and can be run along with the AC and ground wires to the control panel.

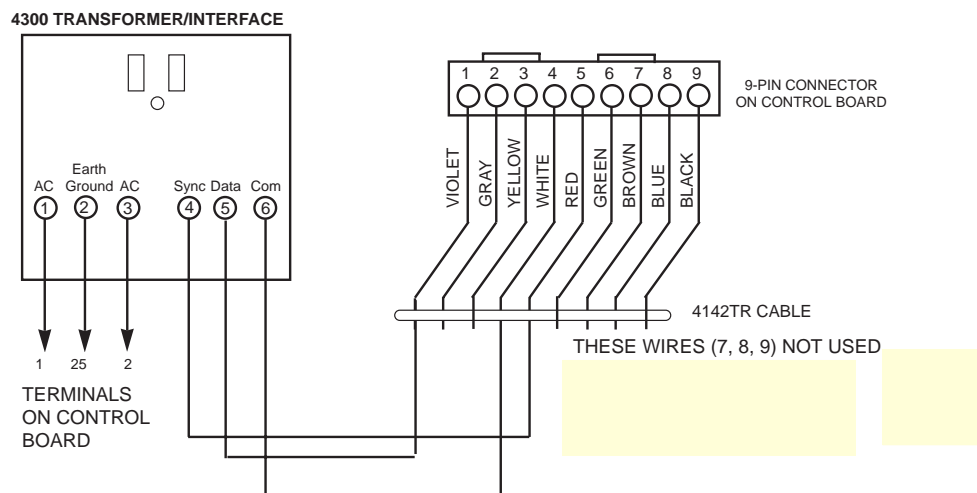



Figure 5. Connections of 4300 Transformer To The Control Board

### Installing The Back-Up Battery

If necessary, refer to the *FINAL POWER UP* section for information regarding battery size to use, etc.

	Do not attach the connector cable to the battery terminals until you are instructed to do so later in the manual.
---	---

1. Place the 12-volt back-up battery in the control cabinet.
2. Attach Red and Black wires on the battery connector cable as follows:
  - a. Red to the positive (+) battery terminal **on the control board** (see Summary of Connections Diagram for location, if necessary).
  - b. Black to the negative (-) battery terminal **on the control board**.

<b>UL</b>	Use a 4AH battery or larger for UL installations.
-----------	---

### Earth Ground Connections

The designated earth ground terminal (25), must be terminated in a good earth ground for the lightning transient protective devices in this product to be effective. The following are examples of good earth grounds available at most installations:

**Metal Cold Water Pipe:** Use a non-corrosive metal strap (copper is recommended) firmly secured to the pipe to which the ground lead is electrically connected and secured.

**AC Power Outlet Ground:** Available from 3-prong, 120VAC, power outlets only. To test the integrity of the ground terminal, use a three-wire circuit tester with neon lamp indicators, such as the UL-Listed Ideal Model 61-035, or equivalent, available at most electrical supply stores.

## Section 3. INSTALLING REMOTE KEYPADS

This section lists the wired keypads that may be used and provides instructions for wiring and mounting the keypads.

A preliminary check-out procedure is also provided to ensure that the connected keypads are functioning properly in the system.

### Keypads That May Be Used

- Fixed-Word Display: 4137AD, 4127, 6127, 6128, 6137
- Alpha Display: 5137AD, 6138, 6139
- Up to 4 keypads in each partition (total of 8 in the system), independent of auxiliary power considerations (you may need to use an auxiliary power supply if the 600mA aux. output is exceeded)



If you are going to use a 4285 Phone Module, you **MUST** use addressable keypads (4137AD, 5137AD, 6128, 6137, 6138, 6139) in the system, but set to the non-addressable mode (address 31).

### Wiring To The Keypads

1. Determine wire gauge by referring to the wiring length/gauge chart below. Wire lengths/gauge for Partition 2 keypads should be determined separately from those keypads connected to Partition 1.

For devices (Keypads, Zone Expander, etc.) connected to a single 4-wire run, determine the current drawn by all units connected to the single wire run, then refer to the Wiring Run chart to determine the maximum wire length that can be safely used for each wire size. Current draw for all devices can be found in the SPECIFICATIONS AND ACCESSORIES section.

**Note:** Refer to “Auxiliary Device Current Draw Worksheet” in the *FINAL POWER UP* section for current draw for all keypads.

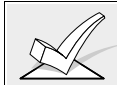

Maximum wire lengths for any device that is homerun to the control can also be determined from the chart, based on the current draw of that device alone.

**Wiring Run Chart For Devices\* Drawing Aux Power From The Control (12V+ & 12V-)**

Wire Size	TOTAL CURRENT DRAWN BY ALL DEVICES CONNECTED TO A SINGLE WIRE RUN				
	50 mA or less	100 mA	300 mA	500 mA	600 mA
#22	500 ft (152m)	250 ft (76m)	80 ft (24m)	50 ft (15m)	42 ft (13m)
#20	750 ft (228.6m)	380 ft (116m)	130 ft (39.6m)	80 ft (24m)	67 ft (20.4m)
#18	1300 ft (396m)	650 ft (198m)	220 ft (67m)	130 ft (39.6m)	115 ft (35m)
#16	1500 ft (457m)	1000 ft (305m)	330 ft (100.5m)	200 ft (70m)	170 ft (52m)

\* Includes Keypads, Zone Expander/Relay Units, or 4285 Phone Module.



The length of all wire runs for both partitions combined must not exceed 1500 feet (457m) when unshielded quad conductor cable is used (750 feet if shielded cable is used). This restriction is due to the capacitive effect on the data lines when quad cable is used.

2. Run field wiring from the control to the keypads (using standard 4-conductor twisted wire cable using the wire gauge determined in step 1).

3. Connect remote Keypads for Partition 1 to terminals 4, 5, 6, and 7 on the control board, as shown in Figure 6.
4. Connect remote Keypads for Partition 2 to the 4-pin connector on the control board (see the Summary of Connections diagram for location of the 4-pin connector for partition 2).

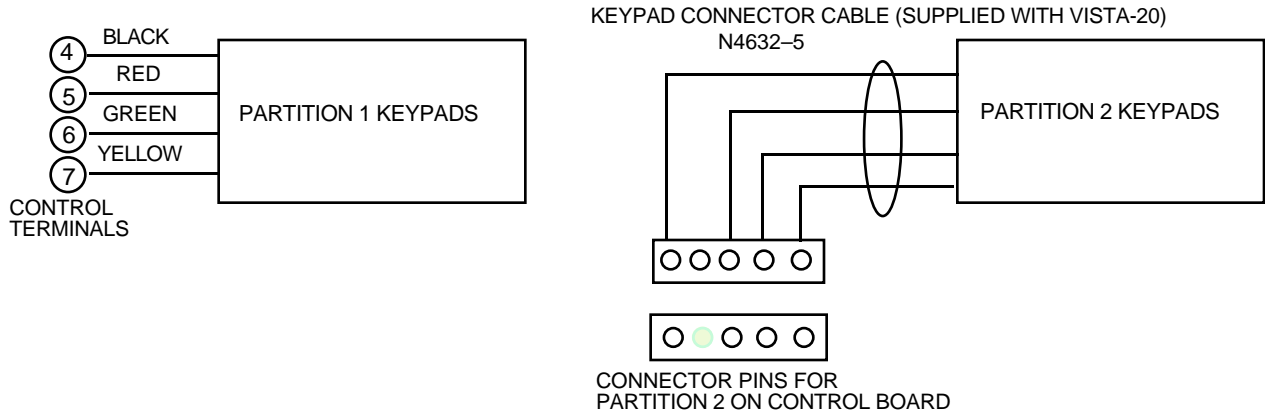

Figure 6. Keypad Connections To The Control Board

#### Mounting the Keypads

1. Make sure addressable type keypads (4137AD, 5137AD, 6128, 6137, 6138, and 6139) are set to non-addressable mode (address 31), which is the factory default setting. Refer to the instructions provided with the keypad for address setting procedure.
2. Mount the keypads at a height that is convenient for the user. Refer to the instructions provided with the keypad for mounting procedure.  
You can either surface mount or flush mount keypads (using an appropriate Trim Ring Kit: 5137TRK or 6139TRK). Refer to the mounting instructions and template included with the keypad and/or trim ring kit for specific information.

#### Using a Supplementary Power Supply to Power Additional Keypads

The control provides 600mA for powering keypads (up to a maximum of 4 per partition) and other devices from the auxiliary power output. The backup battery will supply power to these keypads in the event that AC power is lost.

When the control's auxiliary power load for all devices exceeds 600 mA, you can power additional keypads from a regulated, 12VDC power supply (e.g., 487-12 supplies 12V, 250mA; 488-12 supplies 12V, 500mA). Use a UL Listed, battery-backed supply for UL installations.

The 487-12/488-12 power supplies have a backup battery which can power these keypads in the event of AC power loss.

	Keypads powered from supplies which do not have a backup battery <b>will not function</b> when AC power is lost. Therefore, be sure to power at least one keypad <b>in each partition</b> from the Control's auxiliary power output.
---	--

Connect the additional keypads as shown in Figure 7, using the keypad wire colors shown. Be sure to observe the current ratings for the power supply used.

	Make connections directly to the screw terminals as shown in Figure 7. Make no connection to the keypad blue wire (if present). Be sure to connect the negative (-) terminal on the Power Supply unit to terminal 4 (AUX -) on the control.
---	--

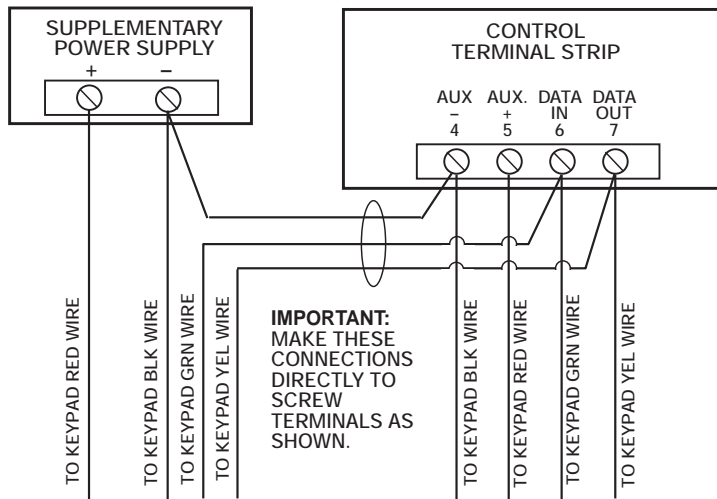

Figure 7. Using A Supplementary Power Supply For Keypads

### Preliminary Check-out Procedure

If you want to check that the system is working before connecting field wiring from zones and devices, do the following:

1. Temporarily connect a 2000 ohm end-of-line resistor across each of the basic hard-wire zones 1–8, as shown in the Summary of Connections diagram.

Without actual zone wiring or EOL resistors connected, the keypads in each partition of the system will not display the “Ready” message.

2. Power up the system temporarily by plugging the AC transformer (previously wired to the control) into a 120VAC outlet.
3. **Busy – Standby** (Alpha keypads) or **dI** (Fixed-word keypads) will be displayed.

After approximately 1 minute\*, the green “READY” LED (or “POWER” LED on some types of keypads) should light, and the word READY (Fixed-word keypads), or DISARMED...READY TO ARM (Alpha keypads) should be displayed.

\* To bypass the 1-minute delay, press [#] plus 0.

If the “Ready” display does not appear on any of the keypads in the system (in either of the partitions), or a “Not Ready” message is displayed, check the keypad wiring connections, and make sure each of the 8 basic hard-wired zones has a 2000 ohm resistor connected across its terminals.

4. When you get the proper “Ready” displays on the keypad(s), the system is functioning properly at this point.

Do not remove the EOL resistors until you are ready to make connections to the hard-wired zones, to allow for testing later in the manual.



If an OC or OPEN CIRCUIT is present on the keypad, data from the control is not reaching the keypad. Please check the wiring.

## Section 4. BASIC HARD-WIRED ZONES 1-8

This section provides general information for the hard-wired zones in the system, plus specific instructions for installing 2-wire smoke detectors, 4-wire smoke/combustion detectors, and 2-wire latching type glass break detectors.

### Installing the Hard-Wired Zones

#### Common Characteristics for Zones 1-8

- Can be assigned to any partition
- EOLR supervised zones supporting both open circuit and closed circuit devices
- As many 4-wire smoke detectors as can be powered from Aux Power on the control (zones 2-7)
- Programmable for 10, 350, or 700 msec response
- 350 msec (default) should be used for most standard contacts. For vibration type contacts, 10 msec is more suitable

#### Wiring Burglary and Panic Devices To Zones 1-8

1. Connect sensors/contacts to the hard-wired zone terminals (8 through 20). See the Summary of Connections diagram .
2. Connect closed circuit devices in series in the high (+) side the loop. The EOL resistor must be connected in series with the devices, following the last device. See the Summary of Connections diagram.
3. Connect open circuit devices in parallel across the loop. The 2,000 ohm EOLR must be connected across the loop wires **at the last device**.

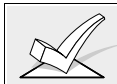

If the EOLR is not at the end of the loop, the zone will not be properly supervised, and the system may not respond to an open circuit on the zone.

#### High Resistance Supervision on Hard-Wired Zones 2-8

- Special supervision in the control senses high resistance on hard-wired zone loops 2-8, causing a warning "CHECK" display with the affected zone number to occur when the system is in the disarmed state. The system cannot be armed when this display is present. If the system is in the armed state when the high resistance condition occurs, no display will take place until the system is disarmed.

#### Wiring 2-Wire Smoke Detectors To Zone 1

1. Connect 2-wire smoke detectors across zone 1 terminals 8 (+) and 9 (-). Observe proper polarity when connecting the detectors.
2. If an EOL resistor is presently connected across zone 1 terminals, remove it. **The EOL resistor must be connected across the loop wires at the last detector.**

**UL**

In UL installations, only zone 1 may be used as a Fire zone. In addition, an Ademco Model 610-7 must be used as an End-of-Line resistor at the last detector.



The alarm current provided by zone 1 will support only one smoke detector in the alarmed state.

#### **"Verify" Operation of 2-Wire Smoke Detectors in Zone 1**

The control panel will "verify" any alarm by resetting the smoke detectors after the first alarm trigger, and then waiting 90 seconds for a second alarm trigger. If the smoke detector or thermostat does not trigger again, the control will disregard the first trigger, and no alarm signal will occur. This feature eliminates false alarms due to electrical or physical transients.

**This feature is available only on units that report to the downloader as Rev 4 or higher.**

**Turning Off Fire Alarm Sounding**

You can turn off Fire alarm sounding by pressing the OFF key on any keypad or other arming/disarming device in that partition. To clear the "memory of alarm" and to reset the detector's alarm, enter the security code plus OFF again.

COMPATIBLE 2-WIRE SMOKE DETECTORS

Detector Type	System Sensor Model No.
Photoelectric w/heat sensor, direct wire	2300TB
Photoelectric, direct wire	2400
Photoelectric w/heat sensor, direct wire	2400TH
Photoelectric	2451 w/B401B base
Photoelectric w/heat sensor	2451TH w/B401B base
Ionization, direct wire	1400

Detector Type	System Sensor Model No.
Ionization	1451 w/B401B base
Photoelectric duct detector	2451 w/DH400 base
Ionization duct detect	1451DH w/DH400 base
Low-profile, Photoelectric, w/135°F thermal	2100T
Low-profile, Ionization type, direct wire	1100

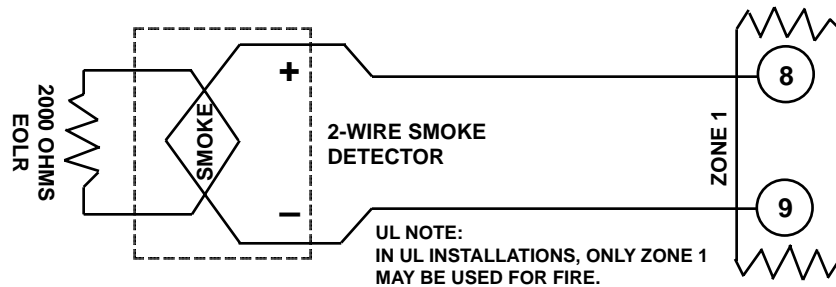

Figure 8. 2-Wire Smoke Detector Connected to Zone 1

Wiring 4-Wire Smoke/Combustion Detectors on Zones 2-7

The system will support as many 4-wire detectors as can be powered from Auxiliary Power on the control on zones 2-7. Refer to the detector's instructions for complete details regarding its proper installation and operation.

1. Connect 12 volt power for the detectors from Auxiliary Power terminals 4 and 5, (which will interrupt power for fire alarm reset). Observe proper polarity when connecting detectors.
2. Connect detectors (including heat detectors, if used) across terminals of the zone selected (zones 2-7 may be used). All detectors must be wired in parallel.

Remove 2000 ohm EOL resistor if connected across the selected zone terminals. You must connect the EOL resistor across the loop wires at the last detector.

3. To supervise power, we recommend the use of a System Sensor No. A77-716B supervisory module.

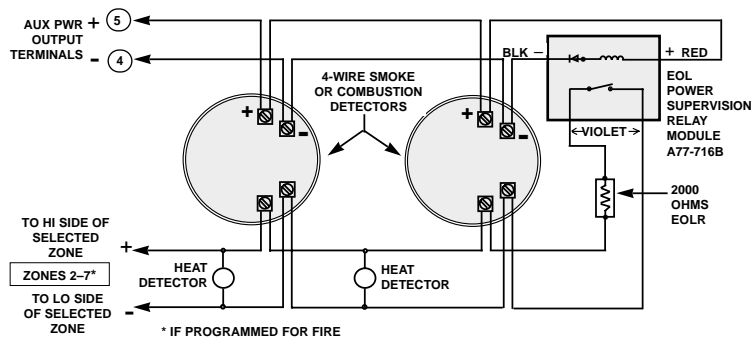

Figure 9. 4-wire Smoke Detector Connections (Zones 2-7)

COMPATIBLE 4-WIRE SMOKE/COMBUSTION DETECTORS	
<b>1412</b>	<i>System Sensor</i> , 4-wire ionization products of combustion detector
<b>2412</b>	<i>System Sensor</i> , 4-wire photoelectric smoke detector
<b>2412TH</b>	<i>System Sensor</i> , 4-wire photoelectric smoke detector w/135° F (57° C) heat detector
<b>A77-716B</b>	<i>System Sensor</i> , EOL relay module (supervisory module for wired 4-wire fire zone).
<b>2112/24T</b>	<i>System Sensor</i> low-profile 4-wire photoelectric smoke detector w/135° F (57° C) heat detector

### Wiring 2-Wire Latching Glass Break Detectors On Zone 8

Use zone 8 for connection of compatible 2-wire latching-type glass break detectors.

After an alarm, the first code + OFF turns off the siren and disarms the system; the second code + OFF clears the memory of alarm and resets the glassbreak detector.

Connect all detectors in parallel across zone 8 (terminals 19 and 20).

	Remove 2000 ohm EOL resistor if connected across the selected zone terminals. You must connect the EOL resistor across the loop wires at the last detector.
---	---

### Compatible Glass Break Detectors

Use detectors that meet the following ratings:

Standby Voltage:	5VDC–13.8VDC
Standby Resistance:	Greater than 20k ohms (equivalent resistance of all detectors in parallel)
Alarm Resistance:	Less than 1.1k ohms (see note below)
Alarm Current:	2 mA–10 mA
Reset Time:	Less than 6 seconds

The IEI 735L series detectors have been tested and found to be compatible with these ratings. You can use up to fifty IEI 735L detectors, connected in parallel.

	You should note that only one detector in the alarmed state can be supported by the alarm current provided by zone 8.
---	---

You can use detectors which exceed 1.1k ohms in alarm, provided they maintain a voltage drop in alarm of less than 3.8 volts.

	Do not use other N.O. or N.C. contacts when using glass break detectors on zone 8. Other contacts may prevent proper glass break detector operation.
---	--

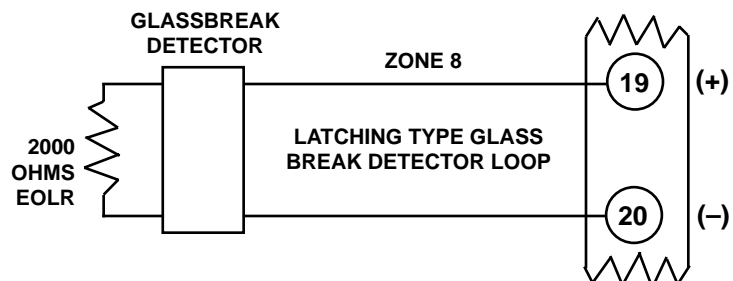

Figure 10. Glass Break Detector Connections To Zone 8

## Programming Hard-Wired Zones

Each zone must be programmed into the system using the \*56 Zone Programming mode, which assigns characteristics that define the way the system responds to faults on that zone. Refer to the Zone Response Type section and the Zone Programming section for specific instructions on programming hard-wired zones.

### Check-Out Procedure For Hard-Wired Zones

After installation and programming of all hard-wired devices is completed, each partition of the security system should be checked, as follows.

1. Make certain that all devices and sensors connected to the hard-wired zones are not in a faulted state. Doors and windows with contacts should be closed, PIRs should be covered (use a cloth to mask them temporarily if necessary).
2. Plug in the AC Transformer if you have not already done so.
3. With all hard-wired zones intact, the Alpha keypad connected to the system should display:

**DISARMED  
READY TO ARM.**

If the following is displayed,

**DISARMED Press \*  
to show faults**

press the [\*] key to display the faulted zone(s). Restore any faulted zone(s) as necessary (also make sure that you have connected a 2000 ohm EOL resistor across the terminals of unused zones).

When the DISARMED...READY TO ARM message is displayed, you can proceed to the next step.

4. Fault and then restore every contact or sensor on each zone individually to ensure that it is being monitored by the system. Each time a zone is faulted, the keypad should display the number of the faulted zone. When each zone is restored, the READY TO ARM message should appear again. If some hard-wired zones have been assigned to partition 1 and others to partition 2, you will need to observe the keypad in the appropriate partition as each zone in that partition is faulted and restored.
5. When you get the proper displays on the keypad(s), the hard-wired zones in the system are functioning properly.
6. Unplug the AC transformer.

# Section 5. WIRED ZONE EXPANSION

This section provides information regarding the use of expansion modules for expanding the number of wired zones in the system, the modules that can be used and their wiring connections.

## Installing Zone Expansion Units

You can add an additional 8 wired EOLR zones to the basic control's 8 zones, for a total of 16 wired zones, by using a No. 4219 Wired Expansion Unit, or 4229 Wired Expansion/Relay Unit.

- Location**
  - You can mount an expansion unit within the control cabinet if space permits. Otherwise, mount the unit outside the cabinet.
- Supervision**
  - Units are supervised against removal. Keypads will display **CHECK** and zone 09 if a zone expander is disconnected.
  - Units have tamper protection for security when mounted outside of the cabinet.
- Zone Information**
  - Assign zone numbers 10–17 for the eight wired expansion loops (designated A to H). You can program these zones individually (in \*56 interactive mode) for Partition 1 or 2. Expansion zones must also be programmed as input type 2 (AW) when prompted.

## Connections and Set-Up

1. Connect the 4219 or 4229 module to the control's keypad terminals (see diagram below).
2. Set the 4219 or 4229's DIP switch for device address "1" (switch 2 "OFF" and switches 3, 4, 5 "ON"). Switch 1 determines expansion zone A's response time ("ON" = normal response, "OFF" = fast response). For location of the DIP switch in the unit, see the diagram below (location of DIP switch for both units is in the same location).

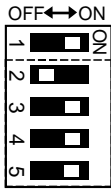

For additional information, see instructions supplied with the 4219 and 4229.

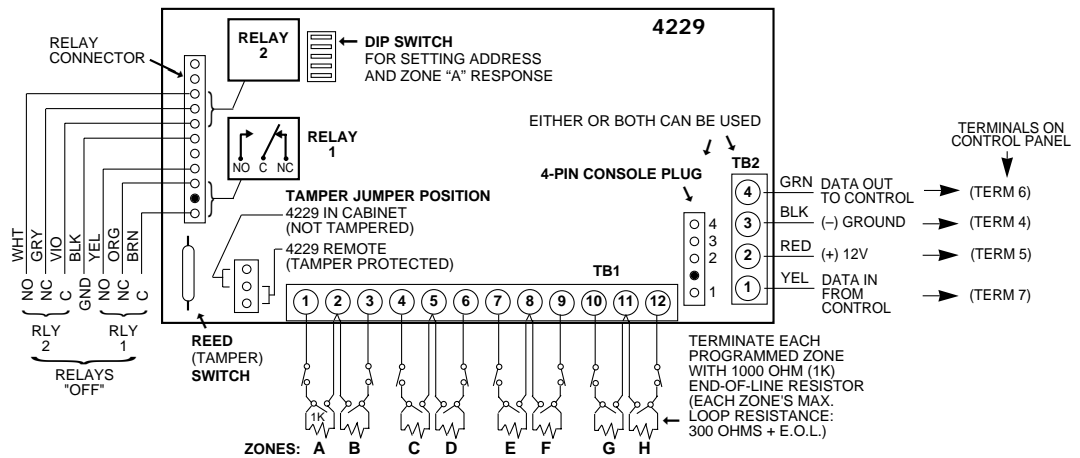

Figure 11. Wiring Connections, 4219 & 4229 (4229 shown)

## Programming Wired Expansion Zones

Each zone must be programmed into the system using the \*56 Zone Programming mode, which assigns characteristics that define the way the system responds to faults on that zone. Refer to the Zone Response Type section and the Zone Programming section for specific instructions on programming wired expansion zones.

### Check-Out Procedure For Wired Expansion Zones

After you have completed installation and programming of all devices, all expansion zones in each partition of the security system should be checked as follows:

1. Make certain that all devices and sensors connected to the wired expansion zones are not in a faulted state. Doors and windows with contacts should be closed, PIRs should be covered (use a cloth to mask them temporarily if necessary).
2. Plug in the AC transformer. With all zones intact (including hard-wired zones), the Alpha keypad connected to the system should display :

**DISARMED  
READY TO ARM.**

If the following is displayed,

**DISARMED Press \*  
to show faults**

press the [\*] key to display the faulted zone(s). Restore any faulted zone(s) as necessary (also make sure that you have connected a 1000 ohm EOL resistor across the terminals of unused expansion zones on the 4219 or 4229 module).

When the READY TO ARM message is displayed, you can proceed to the next step.

3. Fault and restore every contact or sensor in each expansion zone individually to ensure that it is being monitored by the system. Each time a zone is faulted, the keypad should display the number of the faulted zone. When each zone is restored, the READY TO ARM message should appear again.

If some wired expansion zones have been assigned to partition 1 and others to partition 2, you will need to observe the keypad in the appropriate partition as each zone in that partition is faulted and restored.

4. When you get the proper displays on the keypad(s), the wired expansion zones in the system are functioning properly.
5. Unplug the AC transformer.



If a "CHECK 09" message appears on the display, data from the control is not reaching the zone expander module. Check the wiring and DIP switch settings.

# Section 6. RELAY OUTPUTS & POWERLINE CARRIER DEVICES

## Relay/Powerline Carrier Device Basics

Relays and Powerline Carrier devices (ex. X-10 brand devices) are programmable switches that can be used to perform many different functions. They can be used to turn lights on and off, control sounders, or for status indications. In this system, each device must be programmed as to how to act (ACTION), when to activate (START), and when to deactivate (STOP). Each of these is described, and in the programming procedure for \*80 and \*81 interactive modes that are provided in the programming sections of this manual.

The control supports a total of 8 output devices in the following configurations:

- One 4204 relay module (4 relays) and 4 Powerline Carrier devices.
- One 4229 zone/relay module (2 relays) and 6 Powerline Carrier devices.
- Up to 8 Powerline Carrier devices (8 minus the number of output relays used).



A 4204 cannot be used if a 4219 or 4229 is already being used and vice-versa.

The 4204 and 4229 modules provide Form C (normally open and normally closed) contacts. Powerline Carrier devices are controlled by signals sent through the electrical wiring at the premises via a 4300 transformer. Therefore, if using Powerline Carrier Devices, a 4300 transformer must be used in place of the regular system transformer.

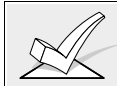

Once a device is programmed into the system, the user sees no difference between a Powerline Carrier device or a relay output device.

In \*80 and \*81 interactive modes, a series of keypad prompts will request entries for programming of the Relay outputs and/or Powerline Carrier devices used in the system. Refer also to "OUTPUT RELAYS/POWERLINE CARRIER DEVICES WORKSHEET FOR \*80 AND \*81 INTERACTIVE MODES" in the blank programming form.

## 4204 and 4229 Relay Modules

### 4204/4229 Setup

The 4204 or 4229 unit can be mounted either remotely or in the control panel. The following steps should be taken to properly set up the 4204 or 4229:

1. Connect the 4204/4229 to the control's Partition 1 remote keypad terminals (4-7), using the connector supplied with the 4204 and 4229. Use standard 4-conductor twisted cable for long wiring runs.
2. Set the 4204/4229's DIP switch for a device address of "1" (switch 2 "OFF" and switches 3, 4, 5 "ON"). Switch 1 determines the unit's cover tamper response ("ON" = disabled, "OFF" = enabled).
3. Connect the desired field wiring to the unit's relay contact terminals.

### Supervision

- 4204 and 4229 modules are supervised against removal. **CHECK** and zone 09 will be displayed if a module is disconnected from the control's terminals (4, 5, 6, & 7).

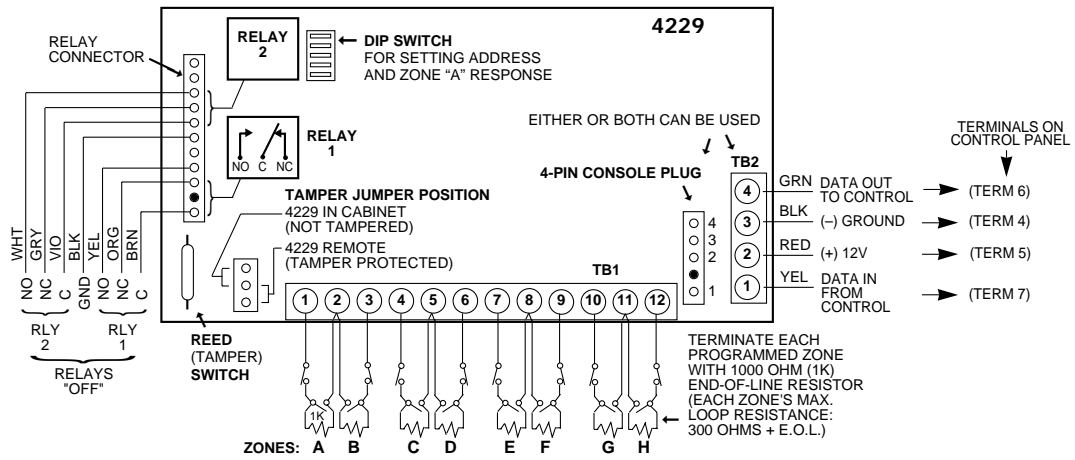

Figure 13. 4229 Connections to Control

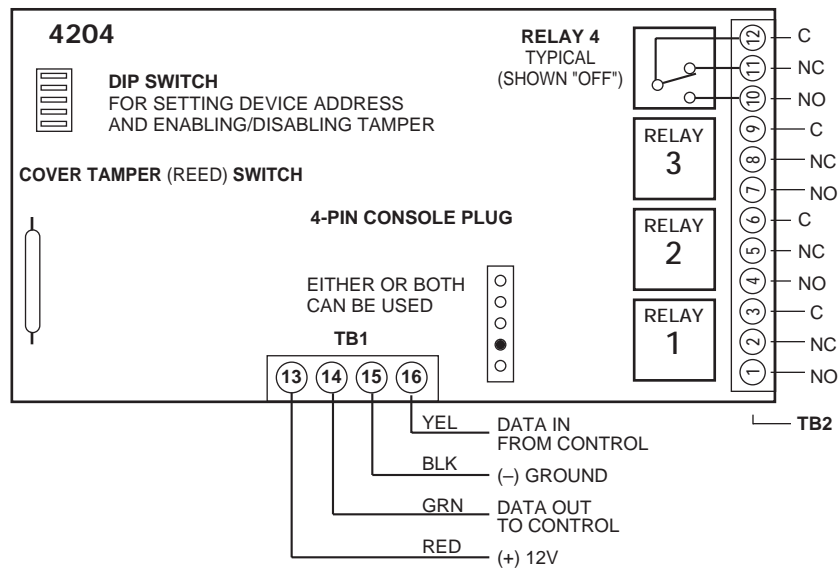



Figure 14. 4204 Connections to Control

Powerline Carrier devices

**UL** Powerline Carrier devices and the 4300 transformer are not UL Listed for fire or burglary functions and are intended for home automation.

 When using Powerline Carrier devices, you must use a 4300 transformer **instead** of the 1321 transformer.

The 4300 transformer provides AC power to the control panel, and also supplies signals from the control panel through the premises AC wiring to the Powerline Carrier devices (which are plugged into AC outlets). Devices plugged into Powerline Carrier devices can then be made to perform various functions in response to commands entered at the keypads in the security system.

## Wiring Connections

1. Splice one end of a 3-conductor cable to the wire ends of the 4142TR cable supplied with the 4300 transformer.
2. Connect the 4142TR cable plug to the 9-pin connector on the control (see SUMMARY OF CONNECTIONS diagram for location of the 9-pin connector).
3. Connect the other end of the 3-conductor cable to the 4300 transformer, as indicated in the table below and in the diagram that follows.

### 4300 TRANSFORMER WIRE CONNECTIONS

4300 Terminal	To Terminal On Control
1 (AC)	1 (16.5V AC in)
2 (Ground)	25 Earth Ground terminal
3 (AC)	2 (16.5V AC in)

4300 Terminal	4142TR Cable Wire
4 (Sync)	RED (Pin 5 of 9-pin connector)
5 (Data)	VIOLET (Pin 1 of 9-pin connector)
6 (Com)	WHITE (Pin 4 of 9-pin connector)

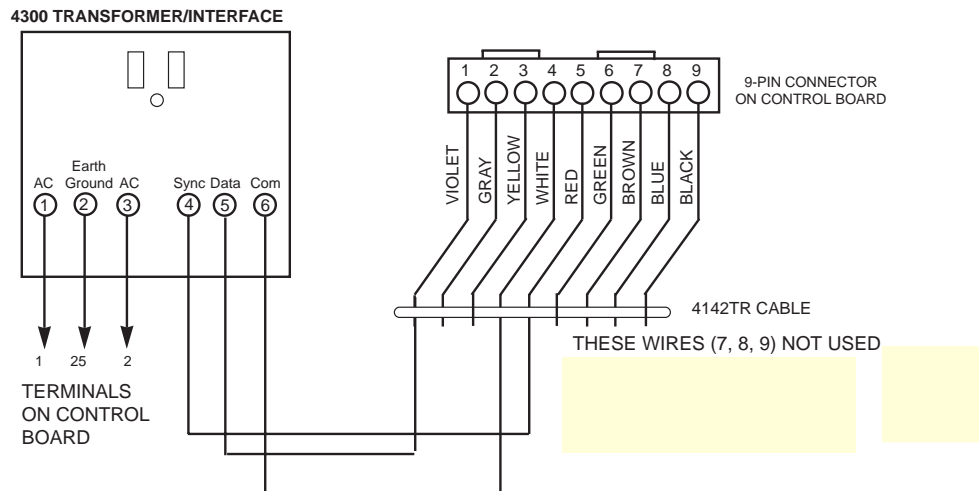

Figure 15. 4300 Transformer Wiring Connections

## Programming Relay Outputs

In this system, each device must be programmed as to how to act (ACTION), when to activate (START), and when to deactivate (STOP). Refer to the programming procedures for \*80 and \*81 interactive modes that are provided in the programming sections of this manual for specific programming details.

## Section 7. 4285 PHONE MODULE

This section provides instructions for mounting and wiring the 4285 Phone Module

### Installing the Phone Module

#### General Information

The 4285 Phone Module is an add-on accessory for the VISTA-20HWSE that permits access to the security system via a Touch-tone phone (either on premises or by a call-in when away).

The Phone Module can announce many of the same words that would normally be displayed on an Alpha keypad under the same system conditions.



- Only one Phone Module can be used in this security system, and only in Partition 1.
- When using the 4285 Phone Module, addressable keypads must be used in the system, but set to the non-addressable mode (address 31),

When properly connected, the 4285 Phone Module will enable the user to do the following via a Touch-tone telephone:

- a. Receive synthesized voice messages over the phone regarding the status of the security system.
- b. Arm and disarm the security system and perform most other commands using the telephone keypad, with voice annunciation being provided over the phone as confirmation after any command is entered.

The phone used for phone access must have Touch-tone capability, though Touch-tone service is not necessary (if premises uses PULSE dialing, switchable phones must be set for Touch-tone temporarily before attempting phone access).

A **Phone Access User's Guide** for phone access to the security system is provided with the Phone Module for the user of the system.

#### Mounting The 4285 Phone Module

The Phone Module may be mounted in the control cabinet if space is available or, if this is not possible, on the side of the cabinet or adjacent to it.

When mounting the Module outside the cabinet, use the screw holes at its rear which will permit it to be mounted horizontally or vertically (2-faced adhesive tape may be used, if preferred). Wires can be brought out from the side or back (a round breakout is also available on the back).

Affix the Phone Module's connections label (supplied separately) to the inside of the Phone Module's cover if the cover is used. If you have installed the module within the cabinet, affix the label to the inside of the control cabinet's door.



If you are also using an Audio Alarm Verification (AAV) unit, refer to the AUDIO ALARM VERIFICATION (AAV) UNIT section for the wiring connections required when using both a Phone Module and an AAV unit. If you are not using an AAV unit, follow the wiring connections indicated in this section for the Phone Module.

## Phone Module Wiring

The 4285 is wired between the control panel and the premises handset(s). It listens for touch tones on the phone line and reports them to the control panel. During on-premises phone access, it powers the premises phones; during off-premises phone access, it seizes the line from the premises phones and any answering machines.

**Note:** The phone lines must be in service for the phone module to function, even when accessing the system from an on-premises phone.

1. Make 12V (+) and (-) and data in and data out connections from the Phone Module to the control, using the connector cable supplied with the Phone Module (see Figure 16).

Color Lead	Terminal On Control *
GREEN	DATA IN (terminal 6)
BLACK	AUX - (terminal 4)
RED	AUX + (terminal 5)
YELLOW	DATA OUT (terminal 7)

\* These are the same connections as those used for remote keypads connected to Partition 1.

2. Insert the keyed connector at the other end of the connector cable into the mating header on the Phone Module (see diagram on next page for location of the header).
3. Connect terminals 1 through 5 on the Phone Module as shown in the Wiring Table below and in the 4285 wiring diagram that follows.



Use an RJ31X jack with a direct-connect cord and make all connections exactly as shown. If the leads on the direct-connect cord are too short to reach their assigned terminals, splice additional wires to them, as required.

**4285 WIRING TABLE**

4285 Terminal	Connects to:
1. Phone In (Tip)	Terminal (21) on control.
2. Phone In (Ring)	Terminal (22) on control.
3. Phone Out (Tip)	BROWN lead from direct-connect cord.
4. Phone Out (Ring)	GRAY lead from direct-connect cord.
5. Ground	Earth ground terminal (25) on control.
6. Not Used	
7. Not Used	



If no touch tones are produced following access to the security system **from on-premises** (this problem may arise in rare cases), it may be necessary to reverse the wires connected to terminals 3 and 4 on the Phone Module **and** the wires connected to terminals (21) & (22) on the control. The wiring diagram shows the wiring connections that will provide proper operation in most cases.

## Caller ID Units

If the telephone system on the premises includes a Caller ID unit, connect the unit **directly to the "Handset" terminals (21 & 22) on the control**, as shown in 4285 Phone Module Wiring Connections diagram that follows.

### 4285 WIRING NOTES:

1. Wire the 4285 Phone Module exactly as shown, using a direct-connect cord and RJ31X jack.
2. If Touch-tones are not heard when pressing keys following phone access to the security system via an on-premises phone, try reversing the pair of wires connected to terminals 3 & 4 on the 4285, **and** the pair of wires connected to terminals 21 & 22 on the control.
3. If an error signal (fast busy signal) is heard when trying to access the system via the phone, check for correct line seizure wiring, as described in note 4.
4. Connection to the incoming Telco line via a RJ31X jack and direct-connect cord, as shown in this diagram, is essential, even if the system is not connected to a central station. **The 4285 will not function if this is not done.**

**The house phone lines (gray and brown wires) must be wired to the Phone Module terminals, not to the control terminals. Otherwise, an error signal (fast busy signal) will occur when trying to access the system from an on-premises phone.**

5. If the telephone system on the premises includes a Caller ID unit, connect the unit **directly** to the "Handset" terminals (21 & 22) on the control, as shown.

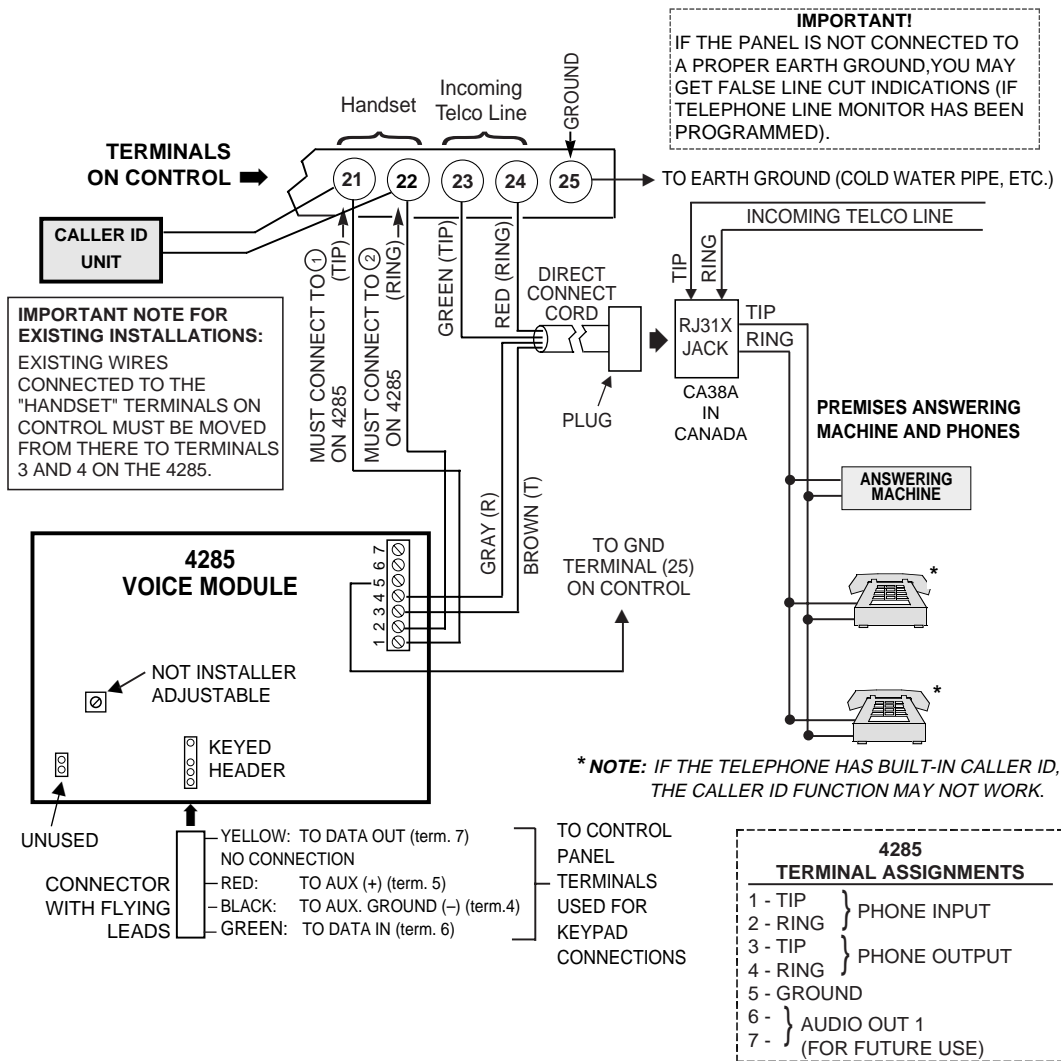

Figure 16. 4285 Phone Module Wiring Connections

## Programming the 4285 Phone Module

The system must be programmed for use with the 4285 Phone Module, including assigning a phone code and selecting words from the alpha vocabulary. Refer to the Programming sections for specific programming details.

### Checking the Operation of the 4285 Phone Module

To Check Phone Module Operation From an On-Premises Phone:

1. Pick up phone and enter the programmed 2-digit phone code. Annunciation of a system status report should automatically start. See the User's Guide accompanying the Phone Module for detailed information regarding the nature of the status report, if necessary.
2. During any pause in the status report, or immediately following it, key the following via the keypad on the phone:  
Installer Code (4112), then press key **1** (OFF).
3. A "beep" should be heard on the phone and from a wired keypad, and the words **DISARMED...READY TO ARM** or **DISARMED...NOT READY TO ARM\*** should be heard, indicating that the command was entered successfully.  
\* DISARMED...NOT READY TO ARM would indicate an open zone.
4. Hang up the phone.

To Check Phone Module Operation From an Off-Premises Phone:

1. Have someone dial the premises phone number, using a TouchTone phone.
  - If the phone system does not include an answering machine, 2 long tones will be heard in the caller's phone, followed by a voice prompt "**HELLO, ENTER PHONE CODE NOW**". The caller should enter the programmed 2-digit phone code.
  - If the premises phone system includes an answering machine, the 2-digit phone code should be entered during a pause at the beginning of, or during, the outgoing answering machine message.
2. When the 2-digit phone code is entered, the caller will hear a voice prompt asking for entry of the 4-digit system code ("**ENTER SYSTEM CODE NOW**").
3. The caller should then enter the installer code (4112). As a safety feature, there is a 3-try limit in which to enter each code (phone code and system code), after which time the call-in will be aborted. Also, if no keys are pressed for a period of 20 seconds, the call-in will be aborted.
4. Annunciation of a system status report will start if both codes were entered correctly.
5. During any pause in the status report, or immediately following it, the caller should key the following via the keypad on the phone:  
Installer Code (4112), then **1** (OFF).
6. A "beep" should be heard (and from a wired keypad on the premises), and the words **DISARMED...READY TO ARM** or **DISARMED...NOT READY TO ARM\*** should be heard on the caller's phone, indicating that the command was entered successfully.  
\* DISARMED...NOT READY TO ARM would indicate an open zone.
7. At this point, the caller can hang up the phone.
8. Verify with the caller that there was successful access to the system and that the appropriate annunciations were heard over the phone.
9. If the Phone Module functioned satisfactorily, unplug the AC transformer from the AC outlet.

## Section 8. EXTERNAL SOUNDERS

This section provides a list of compatible sounders and connection information for an external sounder.

### Compatible Sounders

<b>Ademco AB-12M 10" Motorized Bell &amp; Box</b>	Motor bell & box. UL Grade A. 100 mA current draw.
<b>Ademco 1011BE12M 10" Motorized Bell &amp; Box</b>	Motor bell & box. UL Listed. 100 mA current draw.
<b>Ademco 702 Outdoor Siren</b>	Self-contained 6–12 volt siren (driver built-in) and weatherproof for outdoor use. Can be wired for either a steady or warble sound.
<b>Ademco 719 2-Channel Siren</b>	Two-channel, self-contained 6–12-volt siren (driver built in). 109dB @ 10 feet. 550mA current draw.
<b>Ademco 747 Indoor Siren</b>	Self-contained 12 volt siren (driver built-in) for indoor wall mount. 747F available for flush mounting.
<b>Ademco 747UL Indoor Siren</b>	Self-contained siren (driver built-in) for indoor wall mount. UL Listed.
<b>Ademco 744 Siren Driver</b>	6 jumper-selected sound outputs. Rated at 119dB with use of an 8-ohm 30 watt speaker.
<b>Ademco 745X3 Voice Siren Driver</b>	Voice siren driver with English, Spanish and French voice messages. Separate messages for Fire and Burglary. Use with 8-ohm speaker. UL Listed.
<b>Ademco 705–820, 5-inch Round Speaker</b>	15-watt, 8-ohm speaker.
<b>Ademco 713 Speaker</b>	40-watt, 8-ohm, indoor/outdoor speaker.
<b>System Sensor PA400B (beige)/PA400R (red) Indoor Piezo Sounder</b>	Indoor piezo sounder (red or beige), rated at 90 dB @ 10 feet.

**UL**

- Use only UL Listed sounding devices for UL installations.
- The total current drawn from the alarm output and the auxiliary power output, combined, cannot exceed 700 mA. In addition, the sounding device must be a UL Listed audible signal appliance rated to operate in a 10.2-13.8 VDC voltage range, and must be mounted indoors. Example: Wheelock Signals Inc. siren model 34T-12 (provides 85dB[A] for NFPA 74 & Standard 985).

**This control complies with NFPA requirements for temporal pulse sounding of fire notification appliances.**

Temporal pulse sounding for a fire alarm consists of the following:

3 pulses – pause – 3 pulses – pause – 3 pulses. . .

## Sounder Connections

The VISTA-20HWSE provides a 12 VDC output which can power external alarm sounders (bells or sirens, see compatible sounders listed previously). This output will activate a sounder when an alarm occurs in partition 1 or 2. Make connections to alarm output terminals 3 (+) and 4 (-). See Figure 17.

### Non-UL Installations

The total current drawn from this output cannot exceed 2 amps. A battery must be installed since this current is supplied by the battery.

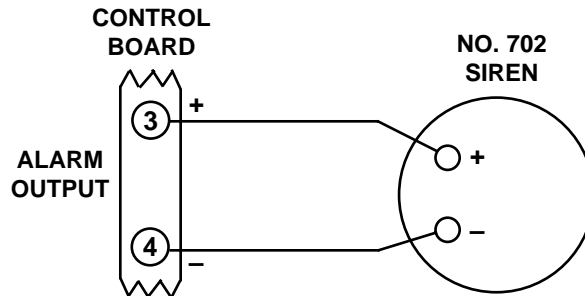
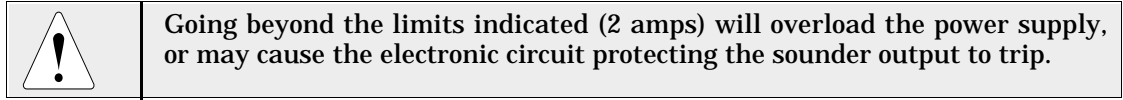

Figure 17. Typical Sounder Wiring

## Testing the Sounder

After installation of the sounder is completed, each partition of the Security System should be carefully tested, as follows.

1. Connect the battery wires from the control board to the battery, observing correct polarity.
2. Enter the installer code (4112) and press the TEST [5] key on the keypad.  
The external sounder should sound for 1 second if the sounder is good and proper connections have been made. Note that if the backup battery is discharged, the sounder will not turn on.
3. To turn off the test mode, enter the installer code (4112) and press the **OFF** key.
4. Disconnect the battery wires from the battery terminals.
5. Unplug the AC transformer from the AC outlet.

## Section 9. LONG RANGE RADIO

### General Information

#### **Check availability of Models 7720 PLUS or 7820 long range radios.**

If output to long range radio is selected, all messages that are programmed to go to the primary telephone line receiver will also be sent to the 7720 PLUS or 7820 long range radio. These messages will be in Contact ID format (not affected by entry in field \*48).

**UL**

For UL installations, Long Range Radio must be disabled (\*29 = "0").

The data line is supervised, as well as certain functions in the radio. If communication is lost or a trouble develops, a message will be attempted to be sent via both radio and telephone to the central station.

For complete information, see the manual that accompanies the radio.

### Connection

Connect the data in/data out terminals and voltage input terminals of the No. 7720 PLUS or 7820 Long Range Radio to the control's keypad connection points, terminals 4, 5, 6, and 7 as shown below.

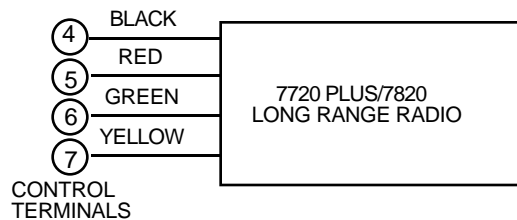

Figure 18. Long Range Radio Connections

# Section 10. AUDIO ALARM VERIFICATION (AAV) UNIT

## General Information

An Audio Alarm Verification (AAV) module, such as the Eagle 1241, is an add-on accessory that permits voice dialog between an operator at a central station and a person at the alarm installation, for the purpose of alarm verification.



In addition to entering option "4" in field \*91 OPTION SELECTION, Contact ID report format must be selected for the primary phone number, and alarm reports must be programmed for the primary phone number to enable the AAV feature.

**UL**

The AAV option cannot be used in UL installations.

After all messages have been sent during a reporting session to the primary phone number, the control will trigger the AAV if at least one of the messages was an alarm report. The control will send a "listen-in to follow" message (Contact ID event code 606), which signals the 685 to hold the phone connection for 1 minute.

Once the digital message is "kissed off", the control will give up the phone line to the AAV module, without breaking connection with the central station. At this time, all sirens and all continuous keypad sounds in all partitions will be shut off.



You must connect a 4204 or 4229 relay module when using an AAV unit. Do not use relay output number 1 for any other usage.

## Wiring Connections

The method used to trigger AAV is via the use of a 4204 or 4229 relay module, as shown in the AAV connection diagrams that follow (one diagram for connections when a 4285 Phone Module is used, the other when the 4285 is not used).

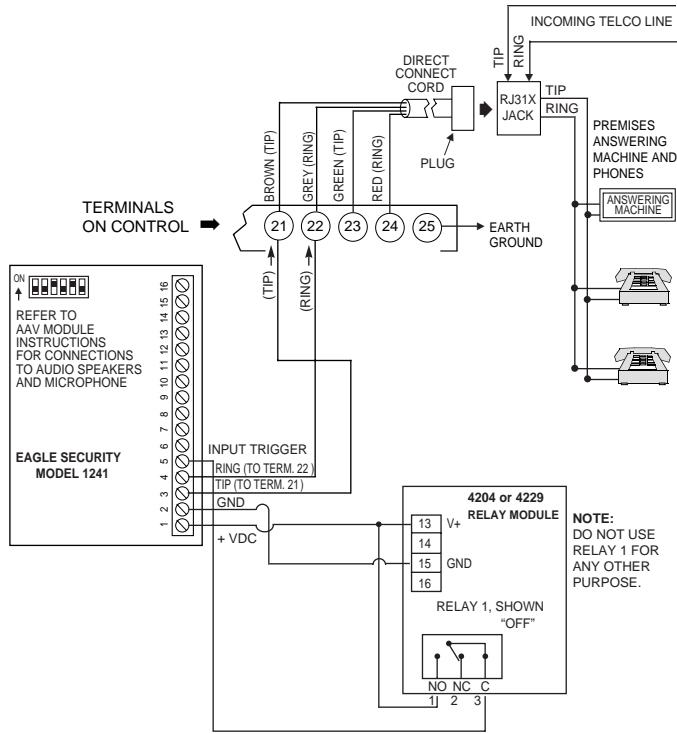

Figure 20. Connection Of AAV Unit When Not Using A 4285 Phone Module

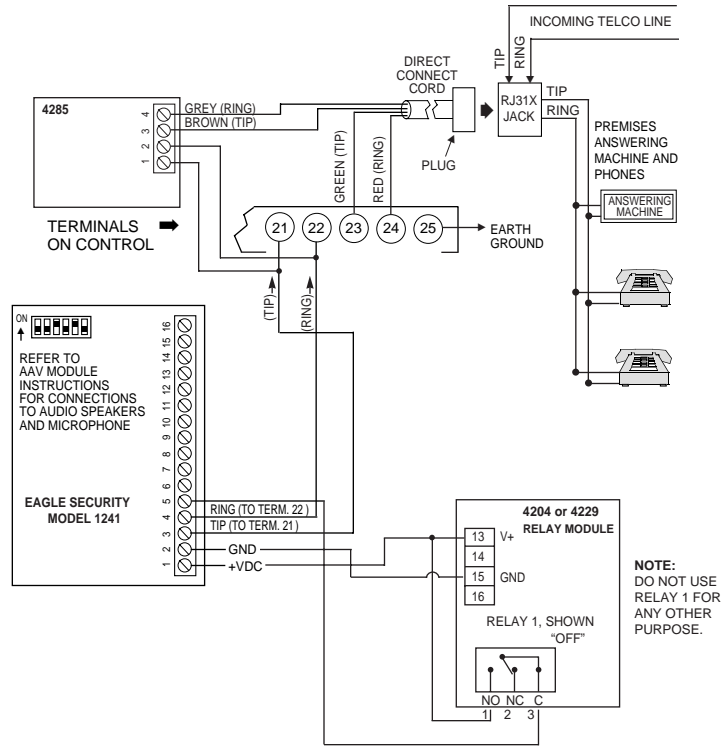

Figure 21. Connection Of AAV Unit When Also Using A 4285 Phone Module

## Section 11. FINAL POWER UP

This section provides information about final power-up procedures and battery size calculations.

### Earth Ground Connections

The designated earth ground terminal (25) must be terminated in a good earth ground for the lightning transient protective devices in this product to be effective. It also must be grounded to enable the telephone line fault indicator to work properly. The following are examples of good earth grounds available at most installations:

**Metal Cold Water Pipe:** Use a non-corrosive metal strap (copper is recommended) firmly secured to the pipe to which the ground lead is electrically connected and secured.

**AC Power Outlet Ground:** Available from 3-prong, 120VAC, power outlets only. To test the integrity of the ground terminal, use a three-wire circuit tester with neon lamp indicators, such as the UL-Listed Ideal Model 61-035, or equivalent, available at most electrical supply stores.

### AC Power-Up

1. Plug the 1321 or 4300 transformer into a 24-hour, uninterrupted 120VAC outlet.
2. Following power-up, **AC**, **dl** (disabled), or **Busy Standby** (Alpha keypads) or **NOT READY** (fixed-word keypads) will be displayed. Also the green "POWER" LED\* on the keypad(s) should light.

\* Some keypads are equipped with a "READY" LED in place of a "POWER" LED.

After approximately 1 minute, the initial displays will revert to **DISARMED...READY TO ARM** for Alpha keypads, or **READY** for Fixed-word keypads (if there are no faulted zones). This 1-minute delay allows PIRs, etc. to stabilize.

To bypass this delay, press: [#] + [0].

### Connecting The Back-Up Battery

In the event of an AC power loss, the Control panel is supported by a back-up, rechargeable gel cell battery. The minimum battery size recommended is the No. 467 (12V, 4AH) battery. See "Calculating Battery Size Needed" below. The battery is installed in the control cabinet.

The standby battery is automatically tested every 4 hours, beginning 4 hours after exiting programming mode. In addition, entry into the test mode will cause a battery test to be initiated.

### Calculating the Battery Size Needed

Determine the total device current draw after filling in the AUXILIARY DEVICE CURRENT DRAW WORKSHEET on the next page. To this figure add the 100 mA that is drawn by the control panel itself. Then, to determine the battery size needed, use the following formula:

Total Current Drawn\* x Number of hours standby wanted = Battery Ampere/Hours.

\* Convert mA figure to decimal Amps (see example).

**Example:** If total auxiliary device current drawn is 450 mA, add 100 mA for the control panel, for a total of 550 mA (0.55 amps); if 24-hour standby is wanted, the calculation will be:

$$0.55 \text{ mA} \times 24 \text{ hours} = 13.2 \text{ Ampere/Hour battery needed.}$$

In this example, two 7 Amp/Hr batteries (connected in parallel) must be used.

### Making the Battery Connections

1. Use the battery standby formula (above) to select the appropriate battery for the installation.

	Do not connect the battery until all devices have been wired to the control.
---	--

2. Attach the Red and Black wires on the battery connector cable as follows:
  - a) Red to the positive (+) battery tab on the control board.
  - b) Black to the negative (-) battery tab on the control board.
 See the SUMMARY OF CONNECTIONS diagram for location of the (+) and (-) battery tabs on the control board.
3. Attach the Red and Black wires at the other end of the battery connector cable as follows:
  - a) Red to the positive (+) terminal on the battery.
  - b) Black to the negative (-) terminal on the battery.

**Battery Tests:** The battery is periodically tested automatically (approximately every four hours), and if it cannot sustain a load, a low battery message is displayed and, if so programmed, will be reported to the central station.

In addition, the connection to the battery is checked every 3 minutes (CSFM requirement). If there is no battery detected, or a low battery condition detected, a low battery message is displayed and a report is sent to the central station.

### AUXILIARY DEVICE CURRENT DRAW WORKSHEET

DEVICE	CURRENT	# UNITS	TOTAL CURRENT
4127 Keypad	20 mA		
4137AD Keypad	60 mA		
5137AD/ADR Keypad	90 mA		
6127 Keypad	20 mA		
6128 Keypad	30 mA		
6137 Keypad	85 mA		
6138 Keypad	100 mA		
6139/6139R Keypad	100 mA		
4219 Zone Expander	35mA		
4204 Relay Unit	15/180mA †		
4229 Zone Expander/Relay Unit	35/100mA †		
4285 Phone Module	160mA		
*			
*			
*			
*			
<b>TOTAL =</b>			
(Current available from Aux. terminals = 600 mA max.)*			

\* If using hard-wire devices such as PIRs, refer to the specifications for that particular unit's current draw.

\*\* In UL installations, maximum current draw from the Auxiliary Output and the Alarm Output **combined** must not exceed 700 mA (600 mA max from Auxiliary Output).

† Figures are for relays OFF/relays ON.

## Section 12. MECHANICS OF PROGRAMMING

This section provides information on how to use the system's programming modes. It will enable you to understand how to enter and exit programming mode, and how to program the data fields and how to use the user-friendly interactive modes (\*56, \*80, \*81, \*82).



If wired expansion will be used, the following program field **must be programmed** (as required) before doing any zone programming.

\*25 WIRED ZONE EXPANSION

In addition, the following fields must be programmed before completing the installation.

\*20 INSTALLER CODE

\*21 QUICK ARM ENABLE

\*23 FORCED BYPASS (**must be disabled for UL installations, enter "0"**).

### General Programming Information

Characteristics for each installation are stored in non-removable, electrically erasable, non-volatile EEROM memory. These must be programmed for the particular installation to establish its specific alarm and reporting features.

It is possible to program the system at any time, even at the installer's premises prior to the actual installation. Simply apply power temporarily to the control and then program the unit as desired.

**IMPORTANT: You cannot enter the programming mode unless both partitions are disarmed.**

There are two programming modes: data field programming and interactive (menu) mode programming. Data field programming is used for setting various system options and interactive programming is used for programming zone information and programming relay outputs.



To program the system, you must use a 5137AD or 6139 2-line Alpha keypad connected to the Partition 1 keypad terminals on the control (4, 5, 6, & 7). **Also, both partitions must be disarmed.** The Alpha keypad need not necessarily remain in the system after programming.

Programming can also be performed remotely from the installer's office/home, using an IBM personal computer, a modem, and V-Link downloading software. See the *REMOTE PROGRAMMING AND CONTROL (DOWNLOADING)* section.

### Entering Program Mode

You may use one of the following methods:

a) Press both the [\*] and [#] keys at the same time **within 50 seconds after power is applied to the Control**, or

b) After power up, enter the Installer code (4 1 1 2) + 8 0 0.

This method is disabled if you exit the program mode using \*98 instead of \*99. See "Exiting Program Mode" paragraph later in this section.

If a different Installer code is subsequently programmed, use it instead of 4112 to gain access to the Programming mode.

Following entry into program mode, data field \*20 will be displayed (this is the first data field in the system). The system will now accept entries for field \*20.

### Programming a Data Field

1. Press [\*] plus Field No. (for example, \*21), then make the required entry.
2. When you have completely programmed a data field, the keypad will "beep" three times and then automatically display the next data field in sequence. To go to a different field, press [\*] plus the desired field No.

3. If the number of digits that you need to enter in a data field is less than the maximum digits available (for example, the phone number field), enter the desired data, then press [\*] and the next data field number to be programmed.
4. If you try to enter a non-existent field, the keypad will display **EE** or **Entry Error**. Simply re-enter [\*] plus a valid field number.

#### Reviewing a Data Field/Erasing an Entry in a Data Field

Press [#] plus Field No. Data will be displayed for that field number. **No changes will be accepted in this mode.**

To delete an entry in a field, press [\*] plus Field No. + [\*]. (Applies only to fields \*40–\*46, and \*94).

#### Interactive Mode Programming (\*56, \*80, \*81, and \*82)

Typical prompt displayed during interactive mode programming

```

Enter Zn Num.
(00 = Quit)      01
Zone Number ↑
```

Press [\*] plus **interactive mode no.** (for example, \*56). The Alpha keypad will display the first of a series of prompts requesting entries. A detailed procedure (with displays of prompts) is provided in later sections of this manual.

Interactive Mode	Used To Program
*56 Zone Programming	Zone characteristics, report codes and alpha descriptors
*80 Relay Programming	4229 or 4204 Relay modules, or Powerline Carrier devices
*81 Zone List Programming	Zone Lists for relay/powerline carrier activation
*82 Alpha Programming	Zone alpha descriptors

#### Loading Factory Defaults

To load the factory defaults, enter the programming mode, press \*97, then exit the programming mode.

	Do not press *97 to load defaults if any programming has been done previously—data already programmed into the system will be changed!
---	--

**\*96** resets all the Subscriber Account numbers and CSID in preparation for an initial download.

#### Programming System Setup Fields

The following program field **must be** programmed before doing any zone programming.

**\*25 WIRED ZONE EXPANSION** 0

Use this field to select the type of expansion unit being used, as follows:  
0 = none; 1 = 4219; 2 = 4229; 3 = 4204. Default is **0**.

#### Exiting the Programming Mode

**\*99** allows re-entry into the program mode using Installer Code + 8 0 0.

**\*98** inhibits re-entry into the programming mode using the Installer code.

# Section 13.

## ZONE RESPONSE TYPE DEFINITIONS

### General Information

You must assign a zone type to each zone, which defines the way in which the system responds to faults in that zone. Zone types are defined below.

**Type 00  
Zone Not Used** Program a zone with this zone type if the zone is not used.

**Type 01  
Entry/Exit Burglary #1** This zone type provides exit and entry delays whenever the zone is faulted if the control is armed in the Away or Stay modes. When the panel is armed in the Instant or Maximum modes, no entry delay is provided. Entry delay #1 is programmable from 0-99 seconds for each partition.

Exit delay begins whenever the control is armed, regardless of the arming mode selected, and is independently programmable from 0-99 seconds (field \*34).

This zone type is usually assigned to sensors or contacts on doors through which primary entry and exit will take place.

**Type 02  
Entry/Exit Burglary #2** This zone type provides a secondary entry delay whenever the zone is faulted if the panel is armed in the Away and Stay modes. When the panel is armed in the Instant or Maximum modes, no entry delay is provided. Entry delay #2 is programmable from 0-99 seconds for each partition.

The programmed exit delay (field \*34) begins whenever the control is armed, regardless of the arming mode selected.

This zone type is usually assigned to sensors or contacts on doors through which secondary entry and exit will take place, and where more time might be needed to get to and from the keypad (typically used for a garage, loading dock, or basement door).

**Type 03  
Perimeter Burglary** This zone type gives an instant alarm if the zone is faulted when the panel is armed in the Away, Stay, Instant or Maximum modes. This zone type is usually assigned to all sensors or contacts on exterior doors and windows.

**Type 04  
Interior, Follower** This zone type gives a delayed alarm (using the programmed Entry/Exit time) if the Entry/Exit zone is faulted first. Otherwise this zone type gives an instant alarm. This zone type is active when the panel is armed in the Away and Maximum modes. **This zone type is bypassed automatically when the panel is armed in the Stay or Instant modes.** This zone type is usually assigned to a zone covering an area such as a foyer, lobby, or hallway through which one must pass upon entry (After faulting the entry/exit zone to reach the keypad to disarm the system.)

Since this zone type is designed to provide an instant alarm if the entry/exit zone is not violated first, it will protect an area in the event an intruder hides on the premises prior to the system being armed, or gains access to the premises through an unprotected area.

**Type 05  
Trouble by Day/  
Alarm by Night** This zone type will give an instant alarm if faulted when armed in the Away, Stay, Instant or Maximum (night) modes. During the disarmed state (day), the system will provide a latched trouble sounding from the keypad (and a central station report, if desired). This zone type is usually assigned to a zone which contains a foil-protected door or window (such as in a store), or to a zone covering a "sensitive" area such as a stock room, drug supply room, etc. This zone type can also be used on a sensor or contact in an area where immediate notification of an entry is desired.

**Type 06**  
**24-hour Silent Alarm**

This zone type sends a report to the Central Station but provides no keypad display or sounding. This zone type is usually assigned to a zone containing an Emergency button.

**Type 07**  
**24-hour Audible Alarm**

This zone type sends a report to the Central Station, and provides an alarm sound at the keypad, and an audible external alarm. This zone type is usually assigned to a zone that has an Emergency button.

**Type 08**  
**24-hour**  
**Auxiliary Alarm**

This zone type sends a report to Central Station and provides an alarm sound at the keypad. **(No bell output is provided)**. This zone type is usually assigned to a zone containing a button for use in personal emergencies, or to a zone containing monitoring devices such as water or temperature sensors, etc.

**Type 09**  
**Supervised Fire**  
**(With Verification on**  
**Zone 1)**

This zone type provides a fire alarm on short circuit and a trouble condition on open circuit. The bell output will pulse when this zone type is alarmed. This zone type is always active and cannot be bypassed. **This zone type can be assigned to a control panel basic wired zone or any zone in a wired zone expansion module.** When used with zone 1 on the panel, 2-wire smoke detectors can be used. For an explanation of the “verification” function, refer to the “Operation” paragraph in a previous section titled **2-Wire Smoke Detector Installation.**

**Note: Only hardwired zone 1 can be programmed as a fire zone in UL installations.**

**Type 10**  
**Interior w/Delay**

This zone type gives entry delay #1 (using the programmed entry time), if tripped when the panel is armed in the Away mode. Entry delay begins whenever sensors in this zone are violated, regardless of whether or not an entry/exit delay zone was tripped first. *No entry delay* is provided if tripped when the panel is armed in the Maximum mode. *Exit* delay is present for *any* arming mode. **This zone type is bypassed when the panel is armed in the Stay or Instant modes.**

**Type 23**  
**No Alarm Response**

This zone type can be used on a zone when an output relay action is desired, but with no accompanying alarm (e.g., lobby door access).

**Type 24**  
**Silent Burglary**

This zone type provides an instant alarm, with NO audible indication at any keypad or external sounder, if the zone is faulted when the system is armed in the AWAY, STAY, INSTANT, or MAXIMUM modes. This zone type is usually assigned to all sensors or contacts on exterior doors and windows where bells and/or sirens are NOT desired. A report is sent to the Central Station.

# Section 14. DATA FIELD DESCRIPTIONS

## Descriptions of System Data Fields

THE BLANK PROGRAMMING FORM SHOULD BE USED TO RECORD THE DATA FOR THIS INSTALLATION

### Defaults (where applicable) Are Indicated In Text

The following pages list all data fields in this control (in numerical order) and serves as a reference for all data fields in the system.

- \*20 INSTALLER CODE**
- The Installer code is used to enter the 4-digit Master security code for each partition in the normal operation mode, via the keypad connected to Partition 1. See "Master Code" in the *SYSTEM OPERATION* section for procedure.  
Enter 4 digits, 0–9.
- \*21 QUICK ARM ENABLE** Partition 1  Partition 2
- 0 = do not allow quick arm  
1 = allow quick arm (the [#] key can be used instead of the security code when arming the system).
- \*23 FORCED BYPASS FUNCTION** Partition 1  Partition 2
- 0 = no forced bypass  
1 = provide automatic bypass of all open (faulted) zones  
All zones bypassed by this function will be displayed after the bypass is initiated.  
UL installations: must be 0 (no forced bypass)
- \*25 WIRED ZONE EXPANSION**
- 0 = no expander module connected  
1 = 4219 connected  
2 = 4229 connected  
3 = 4204 connected
- \*26 CHIME BY ZONE**
- 0 = no (chimes on fault of any entry/exit or perimeter zone when chime mode activated)  
1 = yes (chimes on fault of specific zones programmed in relay zone list 3 when chime mode activated)  
This option allows the installer to define the specific zones intended to chime when faulted while the system is in chime mode.
- \*27 POWERLINE CARRIER DEVICE (X-10) HOUSE ID**
- Powerline Carrier devices require a House ID. This field identifies this House ID to the control.  
If Powerline Carrier devices are used, they are selected in field \* 80.  
House ID is entered in following manner:  
0 = A, 1 = B, 2 = C, 3 = D, 4 = E, 5 = F, 6 = G, 7 = H, 8 = I, 9 = J,  
# + 10 = K, # + 11 = L, # + 12 = M, # + 13 = N, # + 14 = O, # + 15 = P.
- \*28 PHONE MODULE ACCESS CODE**
- 1-9 = first digit of access code  
\* or # = second digit of access code (enter # +11 for "\*", or # +12 for "#")  
The use of a 4285 Phone Module (can be used in Partition 1 only) requires a 2-digit code.  
Example: If desired access code is 7\*, 7 is the first entry, and # + 11 (for \*) is the second entry.  
**NOTE:** A "0" in either digit disables the Phone Module.

- \*29 OUTPUT TO LONG RANGE RADIO** (No. 7720PLUS/7820)
- If output to LRR is selected here, all messages that are programmed to go to the primary telephone line receiver will also be sent to the 7720 PLUS or 7820 radio. These messages will always be in Contact ID format (not affected by entry in field \*48). The data line is supervised as well as certain functions in the radio. If communication is lost or a trouble develops, a message will be attempted to be sent via both radio and telephone to the central station.
- Note:** Normal trouble restore report (\*71) is sent on restore of the condition.
- Entry is first digit of Trouble Dialer Report; enter Trouble code 1-9, B (# +11), C (# +12), D (# +13), E (# +14), or F (# +15). The 2nd digit of Trouble Dialer Report is automatically the 2nd digit from field \*60.
- UL installations: must be 0 (Long Range Radio disabled)
- Note:** The Radio should be programmed for device address 3 on the keypad lines.
- \*31 SINGLE ALARM SOUNDING PER ZONE** (per armed period)
- 0 = no limit on alarm sounding per zone  
1 = limit alarm sounding to once per arming period for a given zone.
- UL installations: must be 0 (no limit)
- \*32 FIRE SOUNDER TIMEOUT**
- 0 = yes, fire sounder timeout after time programmed in field \*33  
1 = no fire sounder timeout; continue sounding until manually turned off
- This control complies with NFPA requirements for temporal pulse sounding of fire notification appliances.
- Temporal pulse sounding for a fire alarm consists of the following:  
3 pulses – pause – 3 pulses – pause – 3 pulses. . .
- \*33 ALARM BELL TIMEOUT**
- 0 = No timeout  
1 = 4 min  
2 = 8 min  
3 = 12 min  
4 = 16 min
- This field determines whether the external sounder will shut off after time allotted, or continue until manually turned off.
- UL installations: must be set for a minimum of 4 min (option 1)
- \*34 EXIT DELAY**
- 00-99 = exit delay time for each partition in seconds  
The system will wait the time entered before sounding an alarm if the exit door is left opened after the system has been armed.
- \*35 ENTRY DELAY 01**
- 00-99 = entry delay time for each partition in secs. Part. 1 Part. 2  
The system will wait the time entered before sounding alarm upon entering.
- UL installations: must be set for a maximum of 20 seconds

**\*36 ENTRY DELAY 02** 6 | 0      6 | 0  
 00-99 = entry delay time for each partition in secs. Part. 1      Part. 2  
 The system will wait the time entered before sounding alarm upon entering.  
 UL installations: must be set for a maximum of 20 seconds

**\*37 AUDIBLE EXIT WARNING** 1      1  
 0 = no exit warning sound      Part. 1      Part. 2  
 1 = provide exit warning sound when armed AWAY

Warning sound consists of slow continuous beeps until last 5 seconds, when it changes to fast beeps. The warning sound will end at the termination of Exit time.

**\*38 CONFIRMATION OF ARMING DING** 0      0  
 0 = no ding      Part. 1      Part. 2  
 1 = confirmation ding after arming system

Confirmation of arming is 1/2 second external sounder "ding" when closing report is sent, or at the end of exit delay.

**\*39 POWER UP IN PREVIOUS STATE** 1  
 0 = always power up in a disarmed state  
 1 = assume the system status prior to power down  
 When the system powers up armed, an alarm will occur 1 minute after arming if a zone is faulted.

Note that if the previous state was armed AWAY or STAY, the system will not respond to sensor changes for 1 minute, which allows time for sensors such as PIRs to stabilize.

UL installations: must be 1 (power up in previous state)

**DIALER PROGRAMMING**  
 (\*40-\*50)

**Fields \*40, \*41, \*42:**  
 Enter up to the number of digits shown. Do not fill unused spaces.  
 Enter 0-9,  
 # + 11 for '\*'  
 # + 12 for '#'  
 # + 13 for a pause (2 seconds)

**\*40 PABX ACCESS CODE** (See Box at Left) | | | | | |  
 Enter up to 6 digits if PABX is needed to access an outside line. If fewer than 6 digits are needed to be entered, exit by pressing [\*] and next field number (e.g., 41). To clear entries from field, press \*40\*.

**\*41 PRIMARY PHONE No.** (See Box at Left) | | | | | | | | | | | | | | | |  
 Enter up to 16 digits. If fewer than 16 digits entered, exit by pressing [\*] and next field number (e.g., 42). To clear entries from field, press \*41\*.

**Note:** Back-up reporting (8 calls are made to the secondary phone number if no kiss-off is received after 8 attempts to the primary number) is automatic only if there is a secondary phone number (field \*42).

**\*42 SECONDARY PHONE No.** (See Box at Left) | | | | | | | | | | | | | | | |  
 Enter up to 16 digits. If fewer than 16 digits entered, exit by pressing [\*] and next field number (e.g., 43). To clear entries from field, press \*42\*. See back-up reporting note for field \*41. If using the pager feature, enter the pager phone number here.

**For Fields \*43, \*44, \*45, and \*46:**

Enter digits 0-9; # +11=B; # +12=C; # +13=D; # +14=E; or # +15=F.

Enter [\*] as the fourth digit if a 3-digit account number (for 3+1 dialer reporting format) is used. Enter 0 as the first digit of a 4-digit account number for Nos. 0000-0999. Exit field by pressing [\*] (and press next field number) if only 3 digits are used.

To clear entries from field, press \*43\*, \*44\*, \*45\* or \*46\*.

See blank Programming Form for examples of Account No. entries.

If using the paging feature, do not enter a leading 0 in the subscriber account number, and do not use digits A-F anywhere in the number. Some paging systems provide voice mail capability, which is activated by a leading 0 in the message.

**\*43 PRIMARY SUBS ACCOUNT. No.** (partition 1)

See box at left.

**\*44 SECONDARY SUBS ACCOUNT. No.** (partition 1)

See box at left.

**\*45 PRIMARY SUBS ACCOUNT. No.** (partition 2)

See box at left.

**\*46 SECONDARY SUBS ACCOUNT. No.** (part. 2)

See box at left.

**\*47 PHONE SYSTEM SELECT**

If Central Station Receiver *is not* on WATS line:

0 = Pulse Dial

1 = Tone Dial

If Central Station Receiver *is* on WATS line:

2 = Pulse Dial

3 = Tone Dial

**\*48 REPORT FORMAT**

0 = 3+1; 4+1 ADEMCO Low Speed Standard

1 = 3+1; 4+1 Radionics Standard

2 = 4+2 ADEMCO Low Speed Standard

3 = 4+2 Radionics Standard

6 = 4+2 ADEMCO Express

7 = ADEMCO Contact ID Reporting

8 = 3+1; 4+1 ADEMCO Low Speed Expanded

9 = 3+1; 4+1 Radionics Expanded

Enter \* as the 4th digit of \*43 through \*46, if 3+1 dialer reporting is to be used.

For an explanation of these formats, see the *SYSTEM COMMUNICATION* section.

**Note:** The maximum number of alarm and alarm restore reports during one armed period is determined by field \*93.

**\*49 SPLIT/DUAL REPORTING**

Use options 0 - 5 when reporting to standard telephone receivers

	TO PRIMARY	TO SECONDARY
0 =	All reports	none, unless primary fails, then all
1 =	Alarms, Restore, Cancel	Others
2 =	All except Open/Close, Test	Open/Close, Test
3 =	Alarms, Restore, Cancel	All
4 =	All except Open/Close, Test	All
5 =	All reports	All

Use options 6 - 9 when reporting to a pager is desired

	TO PRIMARY	TO PAGING No. †
6 =	All reports except Open/Close	Alarms, Open/Close, Troubles
7 =	All reports	Alarms, Troubles
8 =	All reports	Alarms, Open/Close, Troubles
9 =	All reports except Open/Close	Alarms, Open/Close for users 5-16 ‡, Troubles

† Can only be used if primary reporting format is Ademco Contact ID. See explanation of pager report format below.

‡ Open/Close for users 1-4 are not reported.

### Pager Report Format

Options 6-9 send reports to the primary phone number and send reports to a pager, which has its phone number entered as the secondary phone number in field \*42.

The pager report is a 10-digit code in the following format:

SSSS-EEE-NNN

where: SSSS = 4-digit subscriber number (field \*43; first digit cannot be 0)

EEE = 3-digit event code as follows:

911 = alarm (NNN = zone number)

001 = Open, system disarmed (NNN = user no.)

002 = Close, system armed (NNN = user no.)

811 = Trouble (NNN = zone no.)

NNN = 3-digit user number or zone number as described in EEE

Refer to the User Manual for examples of pager displays.

- \*50 15-SECOND DIALER DELAY (BURGLARY)** 0
- 0 = no dialer delay  
1 = provide 15-second delay of burglary alarm report (except zone type 24) to the central station, which allows time for the subscriber to avoid a false alarm transmission. This delay does not apply to zone type 24 alarms, which are always sent as soon as they occur.  
UL installations: must be 0 (no delay)
- \*51 PERIODIC TEST REPORT** 0
- 0 = no test report  
1 = once every 24 hours  
2 = weekly  
3 = once every 30 days  
Test Report Code entered in field \*64 is sent. Reports with Partition 1 Subscriber No.
- \*52 TEST REPORT OFFSET** 2
- 0 = 24 hours after exiting program mode or download  
1 = 6 hours after exiting program mode or download  
2 = 12 hours after exiting program mode or download  
3 = 18 hours after exiting program mode or download  
This is the time to first report from programming or downloading.
- \*53 SESCOA/RADIONICS SELECT** 0
- 0 = Radionics (0-9, B-F reporting)  
1 = SESCOA (0-9 only reporting)  
Select 0 for all other formats.

**TO PROGRAM  
SYSTEM STATUS  
AND RESTORE  
REPORT CODES  
(\* 59 -\* 76, & \* 89)**

Report codes can be programmed using the interactive \*56 Zone Programming Mode, or codes can be entered in data fields \*59-\*76, \*89.

The following is a set of guidelines to be used for programming report codes. The actual report code digits that you enter depend upon the particular installation, and should be in agreement with you and the central station office receiving the signals. Use these guidelines to program this entire section.

**With a 3+1 or 4+1 Standard Format:** Enter a code in the first box: 1-9, A, B, C, D, E, or F. Enter "#+10" for A (this reports a "0" on some receivers), "#+11" for B, "#+12" for C, "#+13" for D, "#+14" for E, "#+15" for F.

An entry of "0" in the *first* box will disable a report.

An entry of "0" in the second box will result in automatic advance to the next field when programming.

**With an Expanded or 4+2 Format:** Enter codes in *both* boxes (1st and 2nd digits) for 1-9, or A-F, as described above.

An entry of "0" in the first box will disable a report.

An entry of "0" in the second box will eliminate the expanded message for that report.

**With Ademco Contact ID Reporting:** Enter a digit in the first box to enable the zone to report. Use a different digit for each zone until you have used up available digits. If the number of zones exceeds the number of available digits, begin with digit 1 again. This is an "enabling" code only and is not the actual code sent to the central station office. Entries in the second boxes will be ignored. For system status (non-alarm) codes, enter a "1" in the first box for all the system conditions you want to send to the central station.

An entry of "0" in the first box will disable the report.

**SYSTEM STATUS  
REPORT CODES  
(\*59-\*68)**

**\*59 EXIT ERROR REPORT CODE** (See box on previous page)

0

If the system is armed and an Entry/Exit or Interior zone is still open after the exit delay time has expired, an alarm will sound at the keypad and external sounder (keypad also displays "Exit Alarm"). If the system is disarmed before the end of the entry delay that immediately follows, the alarm sounding will stop **and no message will be sent to the central station**. The keypad will display CA (fixed-word keypads) or CANCELED ALARM (Alpha keypads).

If the system is **not** disarmed before the end of the entry delay mentioned above, and an Entry/Exit or Interior zone is still open, **an "exit alarm" message will be sent to the central station if an Exit Error Report code is selected in this field**. The keypad will display EA (fixed-word keypads) or EXIT ALARM (Alpha keypads), and the alarm sounding will continue until the system is disarmed (or timeout occurs).

An "Exit Alarm" condition will also result if a fault occurs in an exit or interior zone within 2 minutes following the end of the exit delay, and an "exit alarm" message will be sent to the central station.

If Contact ID format has been programmed, the message will contain the zone number and error code 374 (Trouble-Exit Error) to define the alarm as an Exit Error (rather than E/E or Interior). If 4+2 format is used, the digit entered in this field will be sent followed by the second digit of the programmed alarm code for that zone. If 3+1 or 4+1 format is used, only the digit entered in this field will be sent. This message will go to the Primary Phone No. Under any of these conditions, no Restore message will be sent.

If "0" is entered in this field, no special message will be sent, only the regular alarm and alarm restore code for the zone.

- \*60 TROUBLE REPORT CODE** (See box above)    
 This will be sent if a zone goes into trouble.
- \*61 BYPASS REPORT CODE** (See box above)    
 This will be sent when a zone is manually bypassed. **\*62 AC LOSS REPORT**  
 See box on previous page. Reports with Partition 1 Subscriber No. Timing of this report is random with up to a 4-hour delay. If AC restores before the report goes out, there is no AC restore report.
- \*63 LOW BAT REPORT CODE**    
 This will be sent when a low battery condition exists in the system's standby battery. See box. Reports with Partition 1 Subscriber No.
- \*64 TEST REPORT CODE**    
 This is sent periodically to test that the communicator and phone lines are operational (frequency of report is selected in field \*51). See box. Reports with Partition 1 Subscriber No.
- \*65 OPEN REPORT CODE**   
 This is sent upon disarming of the system. See box. 2nd digit = user number, if expanded or 4+2 reporting is selected.
- \*66 ARM AWAY/STAY REPORT CODE**    
 This option allows for independent programming of AWAY and STAY reports for each partition. 2nd digit of report is user number if expanded or 4+2 reporting is selected.  
**NOTE:** OPEN reports are not sent in if the associated closing report is not enabled.
- \*68 CANCEL REPORT CODE** (See box on previous page.)    
 This is sent upon disarming of the system after an alarm condition was reported.
- RESTORE REPORT CODES (\*70-\*76)**
- \*70 ALARM RESTORE REPORT CODE, 1st DIGIT**   
 This is sent when the zone that caused an alarm is restored to its non-faulted condition. 2nd digit is automatically sent as the 2nd digit of the zone alarm report code programmed in field \*56, if expanded or 4+2 reporting is selected.
- \*71 TROUBLE RESTORE REPORT CODE**    
 See box. This is sent when a trouble in a zone is restored.
- \*72 BYPASS RESTORE REPORT CODE**    
 See box. This is sent when a zone that has been bypassed is unbypassed.
- \*73 AC RESTORE REPORT CODE**    
 This is sent when AC power has been restored after an AC power outage. See box. Reports with Partition 1 Subscriber No.
- \*74 LOW BAT RESTORE REPORT CODE**    
 This is sent when a system low battery condition is restored to normal. See box on previous page. Reports with Partition 1 Subscriber No.
- \*76 TEST RESTORE REPORT CODE**    
 This is sent when the test mode is exited. See box. Reports with Partition 1 Subscriber No. A restore code entered here will cause a restore message to be sent when Test mode is exited.

**\*89 EVENT LOG 80% FULL REPORT CODE** 0 | 0

If an Event Logging selection is made in field \*90, a message can be sent to the central station receiver when the log is 80% full. If the log becomes full, a new message will overwrite the oldest message in the log. **NOTE:** Aside from the selection made by the installer in field \*90, all control and readout from the log is accomplished via the Downloader.

**\*90 EVENT LOGGING** 3

- 0 = No event logging
- 1 = log Alarm/Alarm Restore
- 2 = log Trouble/Trouble Restore
- 4 = log Bypass/Bypass Restore
- 8 = log Open/Close
- x = log combination of events (add value of entries) *Example:* To select "Alarm/Alarm Restore", and "Open/Close", enter 9 (1 + 8); to select all events , enter #15.

The default of "3" = alarm/alarm restore (1) plus trouble/trouble restore (2).

The VISTA-20HWSE system has the ability to record various events in a history log (48-event capacity). The types of events to be logged can be selected as indicated. At any time, the downloader operator can then upload the log and view or print out all or selected categories of the log. The log can also be cleared by the downloader operator.

The display/printout at the central station will show the date, time, event, and description of the occurrences. The time is calculated by an internal clock at the central station computer. Note that the time for any events that occur prior to a system power-down or an entry into the programming mode cannot be calculated by the central station computer. The time will then appear on the log as "unknown".

**NOTE:** System messages are logged when any non-zero selection is made.

**\*91 OPTION SELECTION (Audio Alarm Verification)** 0

- 0 = not using AAV
- 4 = an Audio Alarm Verification (AAV) unit is connected to the system UL installations: must be 0 (AAV disabled)

**\*92 PHONE LINE MONITOR ENABLE** 0

- 0 = Not used
- 1 = Local keypad display only when phone line is faulted
- 2 = Local keypad display plus keypad trouble sound when line is faulted  
Each partition turns off its own trouble sound. No automatic timeout.
- 3 = Same as "2" above plus Device No. 2 STARTS. If either partition is armed, external sounder activates. External sounder will be turned off by normal bell timeout, or by security code plus OFF from either partition (it does not have to be the one that was armed).

**NOTE:** Option 3 may be used even if a relay unit or Powerline carrier device is not connected to the control.

Device number 2 must either be programmed to be STOPPED in field \*80 or STOPPED by entry of security code + [#] + 8 + 2. Partition in \*80 should be set to "0" for STOP.

**NOTE:** This feature will not function properly unless the designated earth ground terminal (25) is connected to an earth ground. If it is not, you may get false line cut indications.

**\*93 NUMBER OF REPORTS IN ARMED PERIOD** 0

- 0 = reports limited to a total of 10
  - 1 = unlimited number of reports
- This option can be used to limit the number of messages (alarm & alarm restore reports) sent to the central station in an armed period.  
UL installations: must be 1 (unlimited reports)

**DOWNLOAD INFORMATION**  
(\*94, \*95)

**\*94 DOWNLOAD PHONE NUMBER**

--	--	--	--	--	--	--	--	--	--	--	--	--	--	--	--

Enter up to 16 digits as follows: 0-9, # +11 for “\*”, # + 12 for “#”, # + 13 for a pause. Do not fill unused spaces. End field by entering \*. To clear entries from field, press \*94\*.

**\*95 RING DETECTION COUNT FOR DOWNLOADING**

0
---

0-15 = number of rings before control picks up phone line

Refer to the chart below and program this field accordingly.

**NOTE:** If "15" is entered in field \*95 to bypass an answering machine, and a 4285 Phone Module is included in the system, you should note the following:  
When calling in from an off-premises phone, the user should make the initial call, allow 1 to 3 rings only, then hang up. The user should then call again. The Phone Module will now seize the line, and 2 long tones sound, followed by the usual voice prompt for the 2-digit access code. If this procedure is not followed, Phone Module operation will not be possible.

Phone Module	Answering Machine	Downloading	Field *95
Yes	No	No	Set for value other than “0” (1-14). This will enable the control panel to answer the phone call. Otherwise, it will not be possible to access the Phone Module
Yes	Yes	No	Set for a value higher than the number of rings for which the answering machine is set. Example: if machine is set for 4 rings, use a value of 5 or higher. This is recommended so that the Phone Module can still be accessed if the answering machine is turned off and does not answer the phone call.
Yes	No	Yes	Set for value other than “0” (1-14).
Yes	Yes	Yes	Enter “15” to bypass answering machine.
No	No	No	Enter “0”.
No	Yes	No	Enter “0”.
No	No	Yes	Enter 1-14.
No	Yes	Yes	Enter 15. See note at left.

**OTHER PROGRAMMING COMMANDS**

**\*56 ZONE PROGRAMMING MODE**

Interactive menu mode used for programming zone attributes and report codes. Refer to *ZONE PROGRAMMING* section for procedure.

**\*80 OUTPUT DEVICES**

Interactive menu mode applicable only if field \*25 is programmed for a 4229, 4204, or if Powerline Carrier devices are being used. Refer to the *OUTPUT DEVICES* section for detailed procedure.

**\*81 ZONE LISTS FOR OUTPUT DEVICES**

Interactive menu mode applicable only if \*25 is programmed for a 4229, 4204, or if Powerline Carrier devices are being used. Refer to the *ZONE LIST* section for detailed procedure.

**\*82 CUSTOM ALPHA EDITING**

Interactive menu mode used to program zone descriptors. Refer to the *ALPHA DESCRIPTION PROGRAMMING* section for procedure.

**\*96 INITIALIZE DOWNLOAD ID AND SUBSCRIBER ACCT. No. FOR DOWNLOADING**

Pressing \*96 initializes the system for downloading.

**\*97 SET ALL PROGRAM FIELDS TO DEFAULT VALUES**

Pressing \*97 automatically loads all defaults and erases any information previously programmed.

**\*98 EXITS PROGRAMMING MODE**

Prevents re-entry by : Installer Code + 8 + 0 + 0  
Allows re-entry only by Power-up then [\*] and [#].

**\*99 EXITS PROGRAMMING MODE**

Allows re-entry to program mode by: Installer Code + 8 + 0 + 0 or by Power-up then [\*] and [#].

# Section 15. ZONE PROGRAMMING (\*56 Menu Mode)

**While in program mode, press \*56 to enter Zone Programming Menu Mode.**

Refer to the zone assignment table for \*56 on the separate programming form.

This is an interactive menu mode that is used to program zone numbers, zone types, partition numbers, alarm and report codes, and to identify the type of loop input device. This mode can also be used for entering Alpha descriptors for zones (we recommend entering descriptors in menu mode \*82).

After entering \*56, the following prompts are displayed:

```

Enter Zn Num.
(00 = Quit)      10
Zone 20 entered ↑
    
```

```

Zn ZT P RC In: L
10 03 1 10 AW: 1
    
```

```

↓ Zone Number
10 Zone Type
Perimeter      03
Zone Type ↑
    
```

**Zone Number (Zn):** Enter the zone number that you wish to program (or 00 to exit zone programming). Press [\*] to continue.

A summary display appears, showing the status of that zone's programming.

If it is programmed satisfactorily, press [#] to back up one step and enter another zone number, if desired.

If the zone is not programmed, or you want to make changes, press [\*] to continue.

**Zone Type (ZT):** Each zone must be assigned to a zone type, which defines the way in which the system responds to faults in that zone.

Enter the zone type code (or change it, if necessary). Zone types are listed below.

- 00 = Not Used
- 01 = Entry/Exit #1
- 02 = Entry/Exit #2
- 03 = Perimeter
- 04 = Interior Follower
- 05 = Trouble Day/Alarm Night
- 06 = 24 Hr Silent
- 07 = 24 Hr Audible
- 08 = 24 Hr Aux
- 09 = Fire W/verif.
- 10 = Interior w/Delay
- 23 = No Alarm Response
- 24 = Silent Burglary

Default values for zones 01 to 08 are:

Zone No.(Zn):	01	02	03	04	05	06	07	08
Zone Type Default:	09	01	03	03	03	03	03	03
Partition Default	1	1	1	1	1	1	1	1
Response Time Default *	1	1	1	1	1	1	1	1

\* "1" for response time = 350 msec.

Press [\*] to continue.

**Partition No. (P)** (Default = [1].

Enter "1" or "2".

Press [\*] to continue.

```

10 Partition
1
    
```

```

10 Report Code
1st 00 2nd 00 00
    
```

**Report Code (RC):** The report code consists of 2 hexadecimal digits, each in turn consisting of 2 numerical digits. For example, for a report code of "3C", enter [0][3] for "3" and [1][2] for "C".

Enter the numbers and press [\*] to continue.

10 INPUT DEV: LP#  
?????????????: 1

**Input Device (In):** For the 8 built-in hardwired zones, the Input Device types are automatically displayed as HW (Panic, Duress, and Tamper inputs are not applicable). For the auxiliary wired zones, enter the input device type as follows:  
2 = AW (auxiliary wired zone)  
Press [\*] to continue.

ZN ZTP RC IN: L  
10 03 1 00 AW: 1 s

The summary screen for the zone will appear. Press [\*] to accept the zone information.

PROGRAM ALPHA?  
0 = NO 1 = YES 0

If you want to program alpha descriptors now, enter "1" (YES). See the *ALPHA DESCRIPTOR PROGRAMMING* section for more information.  
If not, enter "0" (NO).

ENTER ZN NUM.  
(00 = QUIT) 11

This will return you to the ENTER ZN NUM. prompt for the next zone. When all zones have been programmed, enter "00" to quit.



When you have finished programming all zones, test each zone using the system's TEST mode.

## Section 16. OUTPUT DEVICES (\*80 Menu Mode)

### Programming Options Defined

The following will help you understand the programming of Output Devices when using \*80 and \*81 modes. The options used to start and stop these devices are described below, followed by the actual screen prompts and available entries.

The letter(s) in parentheses after each function described below, such as (A) after ACTION, are those that appear in the various summary displays of programmed data during programming.

**ACTION (A)** The "ACTION" of the device is how the device will respond when it is activated by the "START" programming. There are four different choices of actions:

- ACTIVATE for 2 SECONDS and then reset.
- ACTIVATE and REMAIN ACTIVATED until stopped by some other event.
- PULSE ON and OFF until stopped by some other event.
- NOT USED when the device is not used.

**START (STT)** The "START" programming determines when and under what conditions the device will be activated. The following START options are available:

#### Start By Event

1. Event (EV) is the condition (Alarm, Fault, Trouble) that must occur to a zone or group of zones (zone list) in order to activate the device. These conditions apply **only** when a zone list is used. The different choices for "EVENT" are listed below and in the "Programming Output Relays & Powerline Carrier devices" section that follows.
  - ALARM Relay activates upon any alarm in an assigned zone in the zone list.
  - FAULT Relay activates upon any opening or short in an assigned zone in the zone list.
  - TROUBLE Relay activates upon any trouble condition in an assigned zone in the zone list.
  - NOT USED Relay action is not dependent upon one of the above events.
2. Zone List (ZL) is a group of zones to which the "EVENT" applies in order to activate a particular device. Note that there are a total of 3 output device related zone lists that can be programmed in \*81 menu mode; when the selected EVENT (Alarm, Fault or Trouble) occurs in **any** zone in the selected "Start" ZONE LIST (1, 2, or 3), activation of the selected device will START.

#### Start by Zone Type or System Operation

1. If a System Operation, such as "DISARMING" or "ANY FIRE ALARM," is to activate the device, the appropriate choice would also be entered under the "ZONE TYPE" option. "ZONE TYPE" is used independently of the "EVENT/ZONE LIST" combination.

If a "ZONE TYPE" is chosen, any zone of that response type going into alarm, trouble, or fault will cause the device to activate as selected in "ACTION." If the same "ZONE TYPE" is also chosen for the STOP programming, any zone of that type that restores will de-activate the device.

If a "SYSTEM OPERATION" is chosen (e.g., End of Exit Time), that operation will cause the device to activate as selected in "ACTION." The different choices for "ZONE TYPE" and "SYSTEM OPERATION" are listed in "Programming Output Relays & Powerline Carrier devices" later in this section, and in the Programming Form.

- 2 Partition No. (P): The device's "Start" ZONE TYPE/SYSTEM OPERATION may be limited to an occurrence on Partition 1, Partition 2, or any partition (A).

**STOP (STP):** The "STOP" programming determines when and under what conditions the device will be de-activated. The following options are available:

#### **Upon Restore of a Zone List**

1. Restore Zone List (ZL): If a "ZONE LIST" is used as the "Stop" event, the device will de-activate when **all** the zones in that list restore from a previous fault, trouble, or alarm condition. This will occur regardless of what is programmed to "START" the device; therefore, a "RESTORE ZONE LIST" would normally only be used when a "ZONE LIST" is used to start the device.

#### **Upon a Zone Type or System Operation**

1. Zone Type/System Operation (ZT): Instead of using a "RESTORE ZONE LIST", a specific zone (response) type or system operation action can be selected to de-activate the device.

If a specific "ZONE TYPE" is chosen, any zone of that response type that restores from a previous alarm, trouble, or fault condition will cause the device to de-activate.

If a "SYSTEM OPERATION" is chosen, that operation will cause the device to de-activate. The different choices for "ZONE TYPE" and "SYSTEM OPERATION" are listed in "Programming Relays & Powerline Carrier devices" later in this section, and in the Programming Form.

2. Partition No. (P): The device's "Stop" Zone Type/System Operation may be limited to an occurrence on Partition 1, Partition 2, or any partition.



**During normal system operation**, any devices may be manually started by keypad entry of: **Code + # + 7 + "n"** or manually stopped by keypad entry of: **Code + # + 8 + "n,"** where "n" = the device number to be controlled.  
As a minimum, the ACTION (A) and PARTITION No. (P) fields must be programmed for this manual action to be operative.



If a relay is energized before a 4-wire smoke detector is reset, the relay will be stopped by the interruption of Aux. Power that resets the smoke detector. If this is not desired, the power to the relay unit should be supplied from another 12V power source (e.g., the same source that is powering external equipment through the relay contacts).

Programming Output Relays and Powerline Carrier Devices

**While in program mode, press \*80 to enter Output Device Menu Mode.** This mode is used to program all output devices used in the system (4229 or 4204 Relay modules, or Powerline Carrier devices). Refer to the output device table for \*80 on the separate programming form when programming output devices.

**NOTE:** If using Powerline Carrier Devices, the House ID of the devices must be entered in data field \*27.

After entering \*80, the following prompts are displayed.

Output Device Displays [

Enter Device No. (00 = Quit)	01
---------------------------------	----

Enter the Device Number 01 or 02 for a 4229, or 01, 02, 03, or 04 for a 4204, or 01–08 for Powerline Carrier devices (or 00 to end these entries). Press the [\*] key to continue.

The [\*] key is used to accept an entry and advance to the next prompt. The [#] key is used to revert back to the last question to check or change an entry. Press [\*] to go forward again.

02 A EV ZL ZT P STT 0 0 0 00 1
-----------------------------------

This screen displays a summary of the current Device START programming (for this example, device 02 has been selected). Press the [\*] key to continue.

02 A EV ZL ZT P STP - - 0 00 1
-----------------------------------

This screen displays a summary of the current Device STOP programming. Press the [\*] key to continue.

02 Device Action No Response	0
---------------------------------	---

Enter the desired device action as listed below. Press the [\*] key to continue.  
 0 = No response                      2 = Close and Stay Closed  
 1 = Close for 2 seconds          3 = Continuous Pulse on & off (1 sec ON, 1 sec OFF)

02 Start Event Not Used	0
----------------------------	---

Enter the event to START the relay:  
 0 = Not used; 2 = Fault; 1 = Alarm; 3 = Trouble  
 A zone list must be used in conjunction with an event. If a zone type/system operation is to be used instead of an event, enter 0.  
 Press the [\*] key to continue.

02 Start:      Zn List No List	0
-----------------------------------	---

If a zone list will be used to START the relay action, enter the zone list number (to be programmed in field \*81): 1, 2, or 3. If not used, enter 0. Press the [\*] key to continue.

02 Start:      Zn Typ Not Used	00
-----------------------------------	----

If a zone type or system operation will be used to START the device action, enter the appropriate two-digit code (see table that follows). If not, enter 00. Press the [\*] key to continue.

**CHOICES FOR ZONE TYPES**

- |                    |                              |                       |
|--------------------|------------------------------|-----------------------|
| 00 = Not Used      | 04 = Interior Follower       | 08 = 24 Hr Aux        |
| 01 = Entry/Exit #1 | 05 = Trouble Day/Alarm Night | 09 = Fire             |
| 02 = Entry/Exit #2 | 06 = 24 Hr Silent            | 10 = Interior w/Delay |
| 03 = Perimeter     | 07 = 24 Hr Audible           | 24 = Silent Burglary  |

**CHOICES FOR SYSTEM OPERATION**

- |  |                             |                          |                            |
|--|-----------------------------|--------------------------|----------------------------|
| ** Use 0 (Any) for Partition No. (P) entry.    | 20 = Arming–Stay            | 36 = **At Bell Timeout** | 42 = **System Battery Low  |
| *** Or at Disarming, whichever occurs earlier. | 21 = Arming–Away            | 38 = Chime               | 43 = Communication Failure |
|  | 22 = Disarming (Code + OFF) | 39 = Any Fire Alarm      | 52 = Kissoff               |
|  | 31 = End of Exit Time       | 40 = Bypassing           | 58 = Duress                |
|  | 32 = Start of Entry Time    | 41 = **AC Power Failure  |                            |
|  | 33 = Any Burglary Alarm     |                          |                            |

02 Start:	Part
Any Partition	A

Enter (if applicable) the partition number 1 or 2 (or 0 for any).  
Press the [\*] key to continue.

02 Stop:	Zn List
No List	0

If a zone list will be used to STOP, or restore, the device action, enter the zone list number 1, 2, or 3 (to be programmed in \*81 mode). If not used, enter 0.  
Press the [\*] key to continue.

02 Stop:	Zn Typ
Not Used	00

If a zone type or system operation will be used to STOP the device action, enter the appropriate two digit code (see the "ZT" choices listed above). If not, enter 00. Press the [\*] key to continue.

02 Stop:	Part
Any Partition	A

Enter (if applicable) the partition number 1 or 2 (or 0 for any). Press the [\*] key to continue.

02	A	EV	ZL	ZT	P
STT	0	0	0	00	1

This screen again displays a summary of the current device START programming. Press the [\*] key to continue.

02	A	EV	ZL	ZT	P
STP	-	-	0	00	A

This screen again displays a summary of the current device STOP programming. Press the [\*] key to continue.

02	X10 Device ?
0 = No, 1 = Yes	00

Enter 1 if using a Powerline Carrier Device (X-10); if not, enter 0.  
The display then returns again to the first screen so that the next device number to be programmed can be entered, or enter [0][0] to end device programming.

### Example of Output Device Programming

A lamp is to be turned on via a Powerline Carrier device (X-10) when any one of 3 specific zones are faulted, or when any 24-hour auxiliary zone is faulted. We want to be able to turn off the lamp **manually** without affecting the arming status of the system.

To program this, we would do the following:

- In \*80 interactive mode we choose Output Device 01 and program the Action (A) to be "2" (Close and stay closed). The Event we are looking for to *start* the Device action is a fault, so we will program "2" in (EV). We will use Zone List 1 for the 3 specific zones, so we will program "1" in (ZL), (and we will program these 3 zones in \*81's Zone List 1).
- The second condition for turning on the indicator is triggering a 24-hour aux. zone (Zone Type 08), so we will program (ZT) as "08".
- Next, enter the Partition number (P) in which you want the triggering of a 24-hour zone to occur; enter 1 or 2, or enter 0 for *any* partition.
- To stop the Device action and turn off the lamp, we do not want to use a restore of any zone, so a "0" will be programmed for the Restore of Zone List (ZL). We will use a **manual entry of User Code + [#] + [8] + Device #** to turn off. Therefore, we do not need to program a STOP event.  
Press [\*] to continue.
- The system will display a summary screen for the START programming for device 01. Press [\*] to continue.
- The system will display a summary screen for the STOP programming for device 01. Press [\*] to continue.
- The system will display the "X10?" prompt. Enter 1 for yes.
- The **Enter Device No.** prompt for the next zone will be displayed.
- Press 00 and then [\*] to exit the \*80 mode.

Now use \*81 Zone List mode to program the 3 specific zones in Zone List 1.

## Section 17. ZONE LISTS (\*81 Menu Mode)

**While in program mode, press \*81 to enter Zone List Menu Mode.** This mode is used to program zone lists for output devices (programmed in \*80 menu mode) and/or for defining a common zone. Refer to the Programming Form worksheet for \*81 Mode.

### Defining A Common Zone:

A common zone allows either partition to arm the system, while leaving the designated common zone disarmed. This allows access to a disarmed partition without compromising the security of the armed partition.

**To define a zone as a common zone,** simply enter the zone number in zone list 04 using \*81 menu mode as described below.

### Common Zone Notes:

- When using common zones, we suggest the use of the same primary subscriber account number for both partitions 1 and 2. This will help monitoring stations to better track events involving common zones.
- The common zone will sound and report alarms only if **both** partitions are armed (i.e., if one of the partitions is disarmed and the other partition is armed, a fault on this zone will not cause an alarm). When only one partition is armed, the common zone is automatically treated as if it were a zone type 23 (no alarm response) zone.
- A fault on the common zone is displayed in both partitions.
- Either partition may arm its system if the common zone is faulted, but once armed, the other partition cannot arm. That partition must first bypass the common zone or correct the fault before arming.
- Either partition can clear and restore the common zone after an alarm.
- After both partitions arm, exit error logic (if enabled in field \*59) will activate if the common zone remains faulted when exit delay expires.

After entering \*81, the following prompts are displayed.

### Zone List Displays [

Zone List No. (00 = Quit)      01
--------------------------------------

Enter the Zone List Number 01, 02, 03, or 04 to program (or 00 to end these entries). Press the [\*] key to advance.

In the following displays, zone list 01 has been selected for programming.

01    Enter Zn Num. (00 = Quit)      00
--

Enter each zone number to add to the zone list by first entering the zone number, then the [\*] key (example, 01\*, 02\*, 03\*). After all zones desired are entered, press 00 to advance.

01 Del Zn List? 0 = No 1 = Yes    0
--

To delete the zone list, enter 1 (Yes). All zones in the zone list will be deleted automatically. and programming will return to the first screen.

To save the zone list, enter 0 (No) to advance.

01 Delete Zone? 0 = No 1 = Yes    0
--

To save the entire zone list, enter 0 (No) and programming will return to the first screen.

To delete a zone or zones in a zone list enter 1 (Yes) to advance.

01 Zn to Delete? (00 = Quit)      00
---

Enter each zone to be deleted from the list, followed by the [\*] key. After all zones to be deleted are entered, enter 00 to return to the first screen so that another list can be programmed, if desired.

### NOTES:

- Any list may include any or all of the system's zone numbers.
- A zone list can be assigned to more than one output relay.

# Section 18.

## ALPHA DESCRIPTOR PROGRAMMING

This section provides instructions for programming alpha zone descriptors. This is recommended for systems using Alpha keypads, and necessary if a 4285 Phone Module is used.

If using a 4285 Phone Module, select from those words in the Alpha Vocabulary list shown in **boldface type**. **The Phone Module will not provide annunciation of the other words.**



If a 4285 Phone Module is added to an existing VISTA-20HWSE system, the Alpha descriptors presently in the system should be re-programmed, selecting from those words shown in **boldface type** in the Alpha Vocabulary list. The Phone Module will not provide annunciation of any other words.

The ALPHA VOCABULARY LIST and CHARACTER CHART can be found on a following page.

### Zone Descriptors

The Alpha Keypad used with the *VISTA-20HWSE* can have a user-friendly English language description/location of all protection zones, keypad panics, and supervision faults programmed into the system. Each description can be composed of a combination of words (up to a maximum of 3) selected from a vocabulary of 196 words stored in memory (see a following page). In addition, up to 10 installer-defined words can be added to those already in memory. Thus, when an alarm or trouble occurs in a zone, an appropriate description for that zone's location will be displayed at the keypad.

**Note:** Alpha Descriptor entry can be done locally at the Alpha Keypad or remotely using Downloading software. The Alpha keypad procedure is described below.

### Programming Zone Descriptors (program menu mode \*82)

The descriptor can be entered when the zone is being defined in field \*56 but we recommend that it be done using \*82 menu mode.

To program zone descriptors, you simply enter the 3-digit reference number for the desired word(s). The 3-digit number for each word is provided in the Alpha Vocabulary list (on a following page).

1. With the system powered up, enter the programming mode by keying: Installer code (4 1 1 2) + 8 + 0 + 0. The following display will appear:

Installer Code	20
----------------	----

Program Alpha ? 0 = No, 1 = Yes 00
--

Custom Words ? 0 = No, 1 = Yes 00
---

2. **Press \*82.**

The "Program Alpha ?" prompt will appear.

3. **Press "1" (Yes).**

The "Custom Words" prompt will appear.

4. **Press "0" (No).**\* The system will then automatically display the descriptor for zone 1.

\* The procedure for adding custom words to the built-in vocabulary will be found later under "Adding Custom Words".

*Summary Mode Display*

Default Descriptor [

\* ZN 01 ZONE 01

Flashing Cursor (system is ready for entry of word).

\* ZN 01

Flashing Cursor [

\* ZN 01  B ACK

\* ZN 01 BACK

+  
Flashing Cursor if "6" is pressed (system is ready for next word).

\* ZN 01 BACK  
 D OOR

+Flashing Cursor

If a descriptor was not entered previously for zone 1, the default descriptor for zone 1 will be displayed.

Note that this a "summary mode", and that no entries can be made. Entries can be made only when the display contains a flashing cursor, which signifies the "entry mode".

- To delete or change the default descriptor for zone 1, **press \* plus the same zone number (01)**. This will clear that descriptor and allow changes to be made at the flashing cursor.

**NOTE:** If you do not wish to change the existing descriptor for zone 1, enter [\*] plus the next zone number for which you wish to enter (or check) a descriptor. A summary display for that zone will appear. You must then press [\*] plus the same zone number again to gain access to the entry mode (flashing cursor) for that zone.

- Press [#] plus 3-digit number** for the first word from the "Alpha Vocabulary List". Example: The descriptor that we wish to enter for zone 1 is BACK DOOR. From the list, BACK = 013. Therefore, you would enter # **0 1 3**.

**Note:** If you accidentally enter the wrong word, simply press [#] plus the correct 3-digit number for the word you want.

- Press "6" to accept the selected word and continue.**

**NOTE:** If this is the only word you are using for the descriptor, press "8" instead of "6" to save that word in memory, and then go to step 11.

- Enter the 3-digit number for the next word.** In our example, the word is DOOR, whose number is "057".

Enter # **0 5 7**. This display will appear:

\* ZN 01 BACK  
DOOR

+  
Flashing Cursor if "6" is  
pressed (system ready for  
next word).

Summary Display

\* ZN 01 BACK  
DOOR

Program Alpha ?  
0 = No, 1 = Yes  
00

Alpha Pgm 82

9. Press "6" to accept the selected word.

**NOTE:** If these are the only words you are using for the descriptor, press "8" instead of "6" to save them in memory.

10. The two words in our example have now been entered. Note, however, that up to three words may be entered (provided the number of characters will fit on the screen). Press "8" to save all words in memory.

The flashing cursor will disappear, indicating that the word(s) are stored in memory for that zone, as shown in the summary display at the left.

11. To enter a descriptor for the next zone, press \* plus the desired zone number (e.g., \*02. The summary display following step 4 previously will appear. Now repeat steps 6 through 10 for the descriptor for the next zone.

12. To exit the Alpha descriptor mode, press "\*+0+0" at the summary display.

This prompt will be displayed.

13. Press "0". This will be displayed.

14. Press \*99 to exit the programming mode.

## Adding Custom Words (will not be announced by 4285 Phone Module)

You can add up to 10 installer-defined words to the built-in vocabulary. Each of the 10 "words" can actually consist of a "word string" of one or more words, but no more than *ten* characters can be used for each word or word string.

**When adding Custom Words, the keypad keys perform the following functions:**

- [4] Moves cursor one space to the left.
- [6] Moves cursor one space to the right.
- [8] Saves the new word in the system's memory.

1. Perform steps 1, 2, and 3 of **Programming the Descriptors** on a previous page.  
Select CUSTOM WORD mode (enter "1") when the prompt **CUSTOM WORD ?** is displayed.
2. Enter the number ([01]–[10]) of the custom word or word string to be created (for example, if you are creating the first custom word or word-string, enter [01], for the second, enter [02], etc.). A cursor will now appear at the beginning of the second line.
3. Refer to the CHARACTER LIST of letters, numbers, and symbols on a following page.  
Press the [#] key, followed by the two-digit entry for the first letter you would like to display (e.g., [6][5] for "A").  
The cursor will then move to the right, in position for the next character.
4. Repeat step 3 to create the desired word(s). Note that the [4] key can be used to move the cursor to the left, if necessary. Remember, no word or word-string can exceed 10 characters.
5. Press the [8] key to save the custom word(s) and return to the "**CUSTOM WORD ?**" display.

Repeat steps 2–5 for other custom words to be entered. To change a custom word, just overwrite it. If no more are to be entered now, press [0] to return to the Descriptor entry. The custom word(s) will be automatically added to the built-in vocabulary.

When zone descriptors are being entered as described in step 6 of **Programming the Descriptors**, the custom word numbers are 245 to 254 for words 1 to 10 respectively.

## ALPHA VOCABULARY LIST (For Entering Zone Descriptors)

**NOTE:** The list below is a revised vocabulary list which differs from earlier versions of the VISTA-20. Use only this list when programming VISTA-20HWSE zone descriptors.

000 (Word Space)		E	116 LOOP	169 SHOCK	• 227 1
• 001 AIR	• 065 EAST		117 LOW	• 170 SHOP	• 228 1ST
• 002 ALARM	066 ELECTRIC	• 118 LOWER		171 SHORT	• 229 2
004 ALLEY	067 EMERGENCY		M	• 173 SIDE	• 230 2ND
• 005 AMBUSH	068 ENTRY	• 119 MACHINE	174 SKYLIGHT	175 SLIDING	• 231 3
• 006 AREA	• 069 EQUIPMENT	121 MAIDS	• 176 SMOKE	• 178 SONS	• 232 3RD
• 007 APARTMENT	• 071 EXIT	122 MAIN	• 179 SOUTH	180 SPRINKLER	• 233 4
• 009 ATTIC	072 EXTERIOR	• 123 MASTER	• 182 STATION	184 STORE	• 234 4TH
010 AUDIO		124 MAT	• 185 STORAGE	186 STORY	• 235 5
	• 073 FACTORY	• 125 MEDICAL	189 SUPERVISED	191 SUPERVISION	• 236 5TH
• 012 BABY	075 FAMILY	126 MEDICINE	• 182 STATION	192 SWIMMING	• 237 6
• 013 BACK	• 076 FATHERS	128 MONEY	184 STORE	193 SWITCH	• 238 6TH
• 014 BAR	• 077 FENCE	129 MONITOR	• 185 STORAGE		• 239 7
• 016 BASEMENT	• 079 FIRE	• 130 MOTHERS	186 STORY		• 240 7TH
• 017 BATHROOM	• 080 FLOOR	• 131 MOTION	190 SUPERVISED		• 241 8
• 018 BED	081 FLOW	• 132 MOTOR	191 SUPERVISION		• 242 8TH
• 019 BEDROOM	082 FOIL		192 SWIMMING		• 243 9
020 BELL	• 083 FOYER	• 134 NORTH			• 244 9TH
• 021 BLOWER	084 FREEZER	135 NURSERY			
• 022 BOILER	• 085 FRONT		O	194 TAMPER	245 Custom Word #1
023 BOTTOM		• 136 OFFICE	196 TELCO	197 TELEPHONE	
025 BREAK	• 089 GARAGE	• 138 OPEN	199 TEMPERATURE	200 THERMOSTAT	246 Custom Word #2
• 026 BUILDING	091 GATE	• 140 OUTSIDE	201 TOOL	202 TRANSMITTER	247 Custom Word #3
	• 092 GLASS	142 OVERHEAD		205 UP	
028 CABINET	093 GUEST		P	• 206 UPPER	248 Custom Word #4
• 029 CALL	094 GUN	143 PAINTING	• 144 PANIC	• 207 UPSTAIRS	
030 CAMERA		145 PASSIVE	• 146 PATIO	• 208 UTILITY	249 Custom Word #5
031 CAR		147 PERIMETER	• 148 PHONE		
033 CASH	• 095 HALL	150 POINT	151 POLICE	209 VALVE	
034 CCTV	• 096 HEAT	152 POOL	• 153 POWER	210 VAULT	250 Custom Word #6
035 CEILING	098 HOLDUP			212 VOLTAGE	
036 CELLAR	099 HOUSE	155 RADIO			
• 037 CENTRAL		• 156 REAR	R	213 WALL	251 Custom Word #7
038 CIRCUIT	I	157 RECREATION	159 REFRIGERATION	214 WAREHOUSE	
• 040 CLOSED	100 INFRARED	160 RF	• 161 RIGHT	• 216 WEST	
• 046 COMPUTER	• 101 INSIDE	• 162 ROOM	163 ROOF	• 217 WINDOW	252 Custom Word #8
047 CONTACT	102 INTERIOR			• 219 WING	
	103 INTRUSION			220 WIRELESS	
• 048 DAUGHTERS	J	164 SAFE		X	253 Custom Word #9
049 DELAYED	104 JEWELRY	165 SCREEN		222 XMITTER	
• 050 DEN	• 105 KITCHEN	166 SENSOR		Y	254 Custom Word #10
051 DESK		• 167 SERVICE		Z	
• 052 DETECTOR	L	• 168 SHED			
• 053 DINING	• 106 LAUNDRY			224 ZONE (No.)	
054 DISCRIMINATOR	• 107 LEFT			• 225 ZONE	
055 DISPLAY	108 LEVEL				
• 057 DOOR	• 109 LIBRARY		S		
• 059 DOWN	• 110 LIGHT		164 SAFE		
• 060 DOWNSTAIRS	111 LINE		165 SCREEN		
061 DRAWER	• 113 LIVING		166 SENSOR		
• 062 DRIVEWAY	• 114 LOADING		• 167 SERVICE		
• 064 DUCT	115 LOCK		• 168 SHED		

**Note:** Bulleted (•) words in **boldface type** are those that are also available for use by the 4285 Phone Module. If using a phone module, and words other than these are selected for Alpha descriptors, the phone module will not provide annunciation of those words.

### CHARACTER (ASCII) CHART (For Adding Custom Words)

32 (space)	46 .	60 <	74 J	88 X
33 !	47 /	61 =	75 K	89 Y
34 "	48 0	62 >	76 L	90 Z
35 #	49 1	63 ?	77 M	
36 \$	50 2	64 @	78 N	
37 %	51 3	65 A	79 O	
38 &	52 4	66 B	80 P	
39 '	53 5	67 C	81 Q	
40 (	54 6	68 D	82 R	
41 )	55 7	69 E	83 S	
42 *	56 8	70 F	84 T	
43 +	57 9	71 G	85 U	
44 ,	58 :	72 H	86 V	
45 -	59 ;	73 I	87 W	

# Section 19. REMOTE PROGRAMMING AND CONTROL (DOWNLOADING)

## General Information

The VISTA-20HWSE can be remotely programmed from an IBM compatible Personal Computer (PC), a HAYES Modem, and Ademco's V-LINK® Software (as specified below).

**UL**

Downloading may only be performed if a technician is at the site.

Programming the control from a remote location is protected against compromise by someone attempting to defeat the system, using multi-levels of security protection:

- 1. Security Code Handshake:** An 8-digit download ID code must be matched between the control and the downloader .
- 2. Site Initiated Remote Programming:** The installer or subscriber initiates the callback from the subscriber premises (by entering Installer code + # + 1) while disarmed. All parameters can then be downloaded via the phone lines using a personal computer.
- 3. Station Initiated Remote Programming:** The operator calls the site from your office to initiate the download call. The control hangs up and then calls back the PC via the preprogrammed telephone number. The unit can then be uploaded, downloaded, or controlled from your office .
- 4. Telco Hand-off:** Allows the installer or subscriber to perform a download session on the call initiated from the site.
- 5. Data Encryption:** Data passed between the PC and the control is encrypted for security so that it is very difficult for a foreign device tapped into the phone line to take over communication and substitute system compromising information.

## Equipment Required

### At the premises:

- VISTA-20HWSE and keypad.

### At the installer's office/home:

- An IBM PC compatible computer.
- *Either* a HAYES brand SMARTMODEM 1200 [Level 1.2 or higher external or Level 1.1 or higher (with 4 position DIP switch) internal style], *or* a HAYES brand Optima 24 Plus FAX96 Modem.
- V-LINK® Downloading Software Diskette (at revision level supporting the VISTA-20HWSE).
- Appropriate interconnecting cables.

## Initial Download

**Enter Installer code + # + 5.** This sets field \*95 to 4 rings, and system to "no call-back" option. The download computer can then call the subscriber, make connection, and download all programming items.

## Remote Programming Information

The downloading system can perform many functions when in communication with the control unit. Besides uploading and downloading, the status of the system can be observed and various commands can be initiated, as follows:

- Arm the System in the Away Mode; Disarm the System.
- Bypass a Zone.
- Force the System to Accept a New Program Download.
- Shut Down Communication (dialer) Functions (non-payment of monitoring fees in an owned system).
- Shut Down all Security System Functions (non-payment for a leased system).
- Inhibit Local Keypad Programming (prevents account takeover).
- Command the System to Upload a Copy of its Resident Program to the office.
- Read: Arming Status, AC Power Status, Lists of Faulted Zones, Bypassed Zones, Zones Currently in Alarm, Zones Currently in Trouble.

**Notes:** After the control and the PC have established valid communication, each keypad on the system will become inactive and will display "C C" or "MODEM COMM.". The control, however, will still be scanning its zones and looking for alarms. If an alarm does occur, after communication is broken off alarms are sounded and the proper dialer reports are sent to the central station. The keypads will become active after the download communication is terminated. The detailed operation of the download functions is covered in the installation instructions for the V-LINK® Downloading Software Diskette.

## Remote Programming Advisory Notes

- Alarm and trouble reporting may be delayed during the time that the system and the Downloader are linked to each other following a valid exchange of codes, but the proper message will get through to the Central Station after the link is broken.
- Keypad entries are ignored during the time interval stated above.
- A copy of the program downloaded may be produced from the IBM PC compatible computer, using the product's internal report generator, when an optional printer is connected (consult your PC manual for proper printer and connections).
- Program Upload or Download Time—Approximately one minute fifteen seconds for a complete program.

## Section 20. SYSTEM COMMUNICATION

This section provides an explanation of formats this system accommodates for reporting alarms and other system conditions to the central station. The process of a successful transmission consists of both the method of communication between the control panel and the central station receiver and the actual way the information is sent and displayed at the central station.

### Report Code Formats

When the panel calls the central station receiver, it waits to hear a “handshake” frequency from the receiver to confirm that the receiver is on-line and ready to receive its message. Once the panel hears the handshake it is programmed to listen for, it sends its message. The panel then waits for a “kissoff” frequency from the receiver acknowledging that the message was received and understood.

If the handshake frequency is not given or is not understood by the panel, the panel will not send its message. Once the handshake frequency is received and understood by the panel, the panel will send its message. If there is an error in the transmission (the receiver does not receive a “valid” message), the kissoff frequency will not be given by the central station receiver.

The panel will make a total of eight attempts to the primary telephone number and eight attempts to the secondary telephone number (if programmed) to get a valid message through. If the panel is not successful after its numerous attempts, the keypad will display “Communication Failure” (Alpha keypad) or “FC” (Fixed-word keypad).

The following chart defines the three sets of (handshake/kissoff) frequencies that the panel supports and the different formats that can be sent for each.

FORMAT	HANDSHAKE	TRANSMITS DATA	KISSOFF	TRANSMIT TIME
Low Speed 3+1 4+1 4+2	1400Hz	1900Hz (10PPS)	1400Hz	Under 15 secs. (Standard report)
Sescoa/Rad 3+1 4+1 4+2	2300Hz	1900Hz (20PPS)	2300Hz	Under 10 secs. (Standard report)
Express 4+2	1400–2300Hz	DTMF (10 cps)	1400Hz	Under 3 secs.
Contact ID	1400–2300Hz	DTMF (10 cps)	1400Hz	Under 3 secs.

**The following describes each format in greater detail.**

<b>3+1 and 4+1 Standard Formats</b>	Comprise a 3- (or 4-) digit subscriber number and a single digit report code (e.g. Alarm, Trouble, Restore, Open, Close, etc).
<b>3+1 and 4+1 Expanded Formats</b>	Comprise a 3- (or 4-) digit subscriber number, and a two-digit report code. The first digit is displayed on the first line, followed by a second line where the first digit is repeated 3 (or 4) times and followed by the second digit. This is the "expanded" digit.
<b>4+2 Format</b>	Comprises a 4-digit subscriber number and 2-digit report code.
<b>Ademco Contact ID Reporting Format</b>	Comprises a 4-digit subscriber number, 1-digit event qualifier ("new" or "restore"), 3-digit event code, 2-digit Partition No., and 3-digit zone number, user number, or system status number (see the following page).

<b>Report</b>	<b>3+1/4+1 Standard</b>	<b>3+1/4+1 Expanded</b>	<b>4+2</b>
Alarm	SSS(S) A	SSS(S) A AAA(A) Z	SSSS AZ
Trouble	SSS(S) T	SSS(S) T TTT(T) t	SSSS Tt
Bypass	SSS(S) B	SSS(S) B BBB(B) b	SSSS Bb
AC Loss	SSS(S) E	SSS(S) E EEE(E) A <sub>C</sub>	SSSS EA <sub>C</sub>
Low Batt	SSS(S) L	SSS(S) L LLL(L) L <sub>B</sub>	SSSS LL <sub>B</sub>
Open	SSS(S) O	SSS(S) O OOO(O) U	SSSS OU
Close	SSS(S) C	SSS(S) C CCC(C) U	SSSS CU
Test	SSS(S) G	SSS(S) G GGG(G)g	SSSS Gg
Restore Alarm	SSS(S) R	SSS(S) R RRR(R) Z	SSSS RZ
AC Restore	SSS(S) R <sub>A</sub>	SSS(S) R <sub>A</sub> R <sub>A</sub> R <sub>A</sub> R <sub>A</sub> (R <sub>A</sub> )A <sub>C</sub>	SSSSR <sub>A</sub> A <sub>C</sub>
LoBat Res.	SSS(S) R <sub>L</sub>	SSS(S) R <sub>L</sub> R <sub>L</sub> R <sub>L</sub> R <sub>L</sub> (R <sub>L</sub> )L <sub>B</sub>	SSSS R <sub>L</sub> L <sub>B</sub>
Trouble Res.	SSS(S) R <sub>T</sub>	SSS(S) R <sub>T</sub> R <sub>T</sub> R <sub>T</sub> R <sub>T</sub> (R <sub>T</sub> )t	SSSS R <sub>T</sub> t
Bypass Res.	SSS(S) R <sub>B</sub>	SSS(S) R <sub>B</sub> R <sub>B</sub> R <sub>B</sub> R <sub>B</sub> (R <sub>B</sub> )b	SSSS R <sub>B</sub> b

**Where:**

SSS or	SSSS = Subscriber ID	C = Close Code–1st Digit
	A = Alarm Code–1st digit	U = User Number (in hex)
	Z = Typically Zone Number*–2nd digit	Gg = Test Code (1st & 2nd digits)
	Tt = Trouble Code (1st & 2nd digits)	R = Restore Code (Alarm)
	Bb = Bypass Code (1st & 2nd digits)	R <sub>T</sub> t = Restore Code (Trbl)1st & 2nd digits
	EA <sub>C</sub> = AC Loss Code (1st & 2nd digits)	R <sub>B</sub> b = Restore Code (Byps)1st & 2nd digits
	LL <sub>B</sub> = Low Battery Code(1st & 2nd digits)	R <sub>A</sub> A <sub>C</sub> = Restore Code (AC)1st & 2nd digits
	O = Open Code–1st Digit	R <sub>L</sub> L <sub>B</sub> = Restore Code (Bat)1st & 2nd digits
	*Zone numbers for: [*] & [#], or [B] = 99	[1] + [*], or [A] = 95
		[3] + [#], or [C] = 96
		Duress = 92
		Tamper = 9

**Ademco Contact ID Reporting** takes the following format:

CCCC Q EEE GG ZZZ

where: CCCC = Customer (subscriber) ID

Q = Event qualifier, where:

E = new event , and R = restore

EEE = Event code (3 hexadecimal digits)

**Note:** For a complete list of event codes, refer to the central office receiver manual.

GG = Partition Number (system messages show "00")

ZZZ = Zone/contact ID number reporting the alarm, or user number for open/close reports. System status messages (AC Loss, Walk Test, etc.) contain zeroes in the ZZZ location.

**TABLE OF CONTACT ID EVENT CODES**

Code	Definition
110	Fire Alarm
121	Duress
122	Alarm, 24-hour Silent
123	Alarm, 24-hour Audible
131	Alarm, Perimeter
132	Alarm, Interior
134	Alarm, Entry/Exit
135	Alarm, Day/Night
143	Alarm, Expansion Module
146	Silent Burglary
150	Alarm, 24-Hour Auxiliary
301	AC Power
302	Low System Battery/Battery Test Fail
305	System Reset
333	Trouble or Tamper Expansion Module
351	Telco Line Fault
353	Long Range Radio Trouble
373	Fire Loop Trouble

Code	Definition
374	Exit Error Alarm
380	Global Trouble, Trouble Day/Night
401	Disarmed, Armed AWAY (MAX), Armed AWAY
406	Cancel by User
407	Remote Arm/Disarm (Downloading)
408	Quick Arm AWAY/MAX
441	Disarmed/Armed STAY/INSTANT, Quick Arm STAY/INSTANT
570	Bypass
602	Periodic Test
606	AAV to follow
607	System Test
623	Event Log 80% Full
629	1-1/3 Day No Event

# Section 21. SYSTEM OPERATION

## Security Codes

### Installer Code

The installer programs the 4-digit Installer Code initially as part of the programming procedure. The factory default Installer code is "4-1-1-2", but may be changed in field \*20.

The Installer code is the only code that can enter programming mode and also, in normal operation mode, is used to enter the Master code for each partition, which allows access to the normal functions of the system.

### Master Code

**In normal operation mode**, the Installer code is used to enter the 4-digit Master security code for each partition, using *the keypad connected to Partition 1*:

**To enter the Master code for Partition 1**, enter:

Installer Code + [8] + [01] + desired 4-digit Master code for Partition 1

**To enter the Master code for Partition 2**, enter:

Installer Code + [8] + [02] + desired 4-digit Master code for Partition 2

**To change the Master code**, enter:

Current Master code + [8] + [02] + new Master code + new Master code again

### Secondary User Codes

**In normal operation mode**, each partition's Master security code can be used to assign up to 12 secondary 4-digit security codes plus a babysitter code and a duress code for that partition. The master code can also be used to remove secondary codes from the system (individually).

**To assign (or change) a Secondary security code**, enter (*via partition's keypad*):

Partition's Master Code + [CODE key] + User # (03–16)  
+ desired Secondary Code

The system will emit a single beep when each secondary code has been successfully entered.

**To delete a Secondary security code**, enter (*via partition's keypad*):

Partition's Master Code + [CODE key] + User # (03–16)

- Notes:**
- All Master and Secondary security codes permit access to the system for arming, disarming, etc.
  - The installer code can disarm the system only if it was used to arm it.
  - Babysitter code is User code No. 15; i.e., it can disarm the system only if it was used to arm it.
  - Duress code is User code No. 16. When this is used to perform any system operation, a special code is sent to the monitoring station. Instruct users to be careful not to use this code for normal usage.
  - If a secondary code is inadvertently repeated for different users, the lower user number will take priority.
  - Opening and closing reports are sent for the Installer code as No. 01, with the appropriate subscriber number. Each Master code and set of secondary user codes are sent as Nos. 02, and 03–16 respectively in Contact ID format (with the appropriate subscriber number); in 4+2, it is 1-F, "F" for anything greater than 14.

## Keypad Functions

**General Information** Note that if you enabled QUICK ARM for the partition (field \*21), the [#] key can be pressed instead of entering the partition's security code, for any of the arming procedures (Away, Stay, Instant, Maximum, etc.). The security code is always required, however, when disarming the system.

The keypad allows the user to arm and disarm the system, and perform other system functions, such as bypassing zones, and display zone descriptors. Zone and system conditions (alarm, trouble, bypass) are displayed in the Display Window.

When an alarm occurs, keypad sounding and external sounding will occur, and the zone(s) in alarm will be displayed on the keypad. Pressing any key will silence the keypad sounder for 10 seconds. Disarming the system will silence both keypad and external sounders. When the system is disarmed, any zones that were in an alarm condition during the armed period will be displayed (memory of alarm). To clear this display, simply repeat the disarm sequence (enter the security code and press the OFF key) again.

The keypads also feature chime annunciation, and 3 panic key pairs, or individual panic keys (depending on keypad type – see *Panic Keys* below), for silent, audible, fire or personal emergency alarms. These keys can notify the central station of an alarm condition, if that service is connected.

**Arming Functions** The following is a brief list of system commands. For detailed information concerning system functions, refer to the User's Manual.

**Disarmed, Not Ready** .....Before arming, the system must be in the READY condition (all zones must be intact). If the "NOT READY" message appears, press the READY [\*] key to display faulted zones.

**Arming Away** ..... Enter code + AWAY [2].

**Arming Stay** ..... Enter code + STAY [3].

**Arming Instant** ..... Enter code + INSTANT [7].

**Arming Maximum** ..... Enter code + MAXIMUM [4].

**Disarming** ..... Enter code + OFF [1].

**Bypassing Zones** ..... Enter code + BYPASS [6] + zone number(s).

**Forced (Quick) Bypass** ..... (If enabled) To automatically bypass all faulted zones, use the "Quick Bypass" method: Enter code + BYPASS, then wait for all open zones to be displayed. Arm when display indicates "bypass" and "ready to arm".

**Chime Mode** ..... Enter code + CHIME [9].  
To turn chime off, enter code + CHIME again.

### SUMMARY OF ARMING MODES

Arming Mode	Features for Each Arming Mode			
	Exit Delay	Entry Delay	Perimeter Armed	Interior Armed
AWAY	Yes	Yes	Yes	Yes
STAY	Yes	Yes	Yes	No
INSTANT	Yes	No	Yes	No
MAXIMUM	Yes	No	Yes	Yes

Panic Keys There are three panic key pairs or (on some keypads) lettered keys that, if programmed, can be used to manually initiate alarms and send a report to the central station.

Each can be individually programmed for 24-hour Silent, Audible, Personal or Fire Emergency responses. The panic function is activated when both keys of the appropriate key pair are pressed at the same time, or the appropriate lettered key is pressed for at least 2 seconds.

The panic functions are identified by the system as follows:

Keys	Displayed as Zone
[1] & [*], or [A]	95
[*] & [#], or [B]	99
[3] & [#], or [C]	96

**Notes:**

- Keys [A], [B], [C] are not on all keypads.
- Key [D], if present, is not active here.

**Important:** For the Silent Panic functions to be of practical value, the system must be connected to a central station.

Relay/Powerline Carrier Devices  
(if used)

If relay outputs (via a 4204, or 4229), or Powerline Carrier devices are used, two keypad entries available to the user are included. They can manually activate or deactivate the device(s) for starting or stopping some action, such as turning lights on or off, etc.

These keypad entries are:

**Security Code + [#] + [7] + Device #** activates (starts) that device.

**Security Code + [#] + [8] + Device #** de-activates (stops) that device.

4285 Phone Module  
(if used)

Refer to the separate instructions supplied with the Phone Module for information concerning its operating procedures.

**Note:** The Phone Module **cannot** be used to add user codes in this system. User codes must be added by using a wired keypad.

Exit Error Alarm Displays  
(if programmed)

- **A display of "CANCELED ALARM" or "CA" and a zone indication** will appear if an exit or interior zone contained a fault during closing at the time the exit delay ended (e.g., exit door left open), **but the system was disarmed during the entry delay time.** The alarm sounder and keypad sound continuously, but stop when the system is disarmed. No message will be transmitted to the central station.
- **A display of "EXIT ALARM" or "EA" and a zone indication** will appear if an exit or interior zone contained a fault during closing at the time the exit delay ended, **but the system was NOT disarmed during the entry delay time.** The alarm sounder and keypad sound continuously until the system is disarmed (or timeout occurs). An "exit alarm" message is sent to the central station.
- **The "EXIT ALARM" display, etc.** will also result if an alarm from an exit or interior zone occurs within two minutes after the end of an exit delay.

In any of the above cases, use a second OFF sequence (code plus OFF key) to clear the display.

## Trouble Conditions

### (See Troubleshooting Guide also)

General Information	<p>The word "CHECK" on the Keypad's display, accompanied by a rapid "beeping" at the Keypad, indicates that there is a trouble condition in the system. The audible warning sound can be silenced by pressing any key. Instruct users to call for service immediately upon seeing any of the following messages.</p>
"Check" and "Battery" Displays	<ul style="list-style-type: none"><li>• <b>A display of "CHECK" and one or more zone numbers</b> indicates that a problem exists with the displayed zone(s) and requires attention. <b>Note:</b> The control will sense a high resistance in the loops on hard-wired zones 2–8 and display "CHECK" and the affected zone number when the system is in the disarmed mode. It will not be possible to arm the system as long as this condition exists (unless this zone is bypassed). If the system is in the armed mode when the high resistance condition occurs, this display will not appear, but will do so as soon as the system is disarmed. Check the sensor or the loop wiring for the displayed zone. When the problem has been corrected, the display can be cleared by entering the OFF sequence (code plus OFF key) twice.</li><li>• A display of "CHECK" and <b>09</b> indicates that communication between control and a zone expander is interrupted. Check the wiring and DIP switch settings on the units.</li><li>• <b>A display of "BAT"</b> (Fixed-word keypads) <b>or "SYSTEM LO BAT"</b> (Alpha keypads) <b>with no zone number</b> indicates that the system's main standby battery is weak.</li></ul>
Telephone Line Failure	<p>A display of "94" (Fixed-word keypads), or "Telco Fault" (Alpha keypads), indicates that a monitored telephone line (if programmed in field *92) has been cut (or disconnected). Depending on how the system was programmed, the keypad may also produce a trouble sound, and the external sounder may be activated (silence by entering installer code plus OFF).</p>
Power Failure	<ul style="list-style-type: none"><li>• <b>If there is no keypad display at all, and the POWER indicator (if present) is not lit</b>, operating power for the system has stopped and the system is inoperative.</li><li>• <b>If the message "AC LOSS"</b> (Alpha keypads) <b>or "NO AC"</b> (Fixed-word keypads) <b>is displayed, and the POWER indicator (if present) is off</b>, the keypad is operating on battery power only.</li><li>• <b>If the battery standby capacity is used up during a prolonged AC power outage</b>, the control's auxiliary power will shut down to minimize deep discharge of the battery.</li></ul>
Other Displays (Fixed Word displays are in parentheses)	<p><b>Busy-Standby (dl)</b>. If this remains displayed for more than 1 minute, the system is disabled.</p> <p><b>Modem Comm (CC)</b> The system is in communication with the central station for change of function or status verification.</p> <p><b>Comm. Failure (FC)</b> A communication failure has occurred.</p> <p><b>Open Circuit (OC)</b> The keypad is not receiving signals from the control and sees an open circuit.</p> <p><b>Long Rng Trbl (bF)</b> Back-up LRR communication failure.</p>

## Section 22. TESTING THE SYSTEM

### Test Procedure

After installation is completed, each partition of the Security System should be carefully tested, as follows.

1. With the System in the disarmed state, check that all zones are intact. If a **NOT READY** message is displayed, press the [\*] key to display the faulted zone(s). Restore faulted zone(s) if necessary, so that **READY** message is displayed. Fault and restore every sensor individually to assure that it is being monitored by the system.
2. Enter the **security code** and press the **TEST** key. The outside sounder will sound for 1 second. The keypad should sound 3 beeps each time a contact is faulted. A test report should be transmitted (if programmed) to the Central Station immediately. If the backup battery is discharged or missing, the sounder may not turn on and a **LOW BATTERY** report will be transmitted with a **TEST** report. The keypad will beep once per minute as a reminder that the system is in the Test Mode. To turn off the test mode enter **security code** and press the **OFF** key.

**Alarm messages will be sent to the central station during the following tests 3 and 4. Notify them in advance that tests will be in progress.**

3. Arm the system and fault one or more zones. After 15 seconds (if optional dialer delay is selected), silence alarm sounder(s) by entering the **code** and pressing **OFF**. Check Entry/Exit delay zones.
4. Check the keypad-initiated alarms that are in the system by pressing the Panic key (key pairs on some keypads). If the system has been programmed for audible emergency, the keypad will emit a steady alarm sound, and **ALARM and zone number** will be displayed. Silence the alarm by entering the **security code** and pressing **OFF**.  
If the system has been programmed for silent emergency, there will be no audible alarms or displays, but a report will be sent to the central station.
5. If output Relay Units/Powerline Carrier Devices have been installed, test their programmed action.
6. Notify the central station when all tests are finished, and verify results with them.

**NOTE:** THE TEST MODE WILL BE AUTOMATICALLY TERMINATED AFTER 4 HOURS IF THE INSTALLER OR USER DOES NOT MANUALLY TERMINATE IT.

This insures that Fire and Panic zones will not remain disabled.

#### TO THE INSTALLER

Regular maintenance and inspection (at least annually) by the installer and frequent testing by the user are vital to continuous satisfactory operation of any alarm system.

The installer should assume the responsibility of developing and offering a regular maintenance program to the user as well as acquainting the user with the proper operation and limitations of the alarm system and its component parts. Recommendations must be included for a specific program of frequent testing (at least weekly) to insure the system's proper operation at all times.

## Section 23. TROUBLESHOOTING GUIDE

### SYSTEM

SYMPTOM	POSSIBLE CAUSE	REMEDY
1. <b>Low Battery message on keypad.</b>	1. "Bat" or "System Lo Bat" (no zone Nos.)	1. System battery is low or missing.
2. <b>Periodic beep(s) from keypad.</b>	2. System is in TEST mode.	2. Enter "Code" + OFF to exit TEST mode.
3. <b>Nuisance or phantom alarm.</b>	3. Sensors not properly installed, wired, or monitored.	3. Check installation to see if in accordance with established procedure.
4. <b>Intrusion alarm for no apparent reason.</b>	4a. Protected door or window opened while system armed. 4b. Improper user operation of exit/entry delays. 4c. Magnets located too far from switches, and/or doors and windows not properly aligned.	4a. Check with all occupants of protected home. 4b. Check setting of entry and exit delays . 4c. Check all openings for proper switch and magnet orientation.
5. <b>"CHECK" and zone number 2-8 is displayed.</b>	5. Control has sensed a high resistance condition on a loop in one of the hard-wired zones (2-8).	5. Check the sensor or the loop wiring in the affected zone. The system will not arm until this condition is corrected (or the affected zone is bypassed).

### CONTROL

SYMPTOM	POSSIBLE CAUSE	REMEDY
1. <b>"AC POWER" light off.</b>	1a. Interrupted AC power supply.	1a. Check transformer connection and Powerline circuit breaker.
2. <b>Digital communicator message not being received.</b>	2a. VISTA-20HWSE in TEST mode. 2b. Telephone connection not secure. 2c. Digital communicator malfunctioning. 2d. Telephone number in program needs prefix or access code. 2e. Telephone call to central monitoring station requires operator assistance.	2a. Remove from TEST mode. 2b. Check all connections. 2c. Check with a different VISTA-20HWSE. 2d. Program prefix or access code into the VISTA-20HWSE. 2e. VISTA-20HWSE system cannot work in this situation.
3. <b>Does not arm properly.</b>	3a. Ready light not on.	3a. Check for faulted zones and make intact, or use Bypass arming, if desired.
4. <b>VISTA-20HWSE doesn't respond to keystrokes on keypad.</b>	4a. "CC" or "MODEM COMM" displayed. 4b. "d1" or "System Busy" displayed. 4c. Keypad address setting incorrect.	4a. System is in communication with downloader at central station. Wait until download session is finished. 4b. System has just been powered and is in its one minute initialization. To bypass this time, press '#' + '0'. 4c. Keypads must be set for address 31 (non-addressable mode).

### SMOKE DETECTOR

SYMPTOM	POSSIBLE CAUSE	REMEDY
1. <b>Detector alarms, no apparent reason.</b>	1a. Dust, dirt in sensing chamber. 1b. Improper location. 1c. Unit malfunctioning.	1a. Clean unit's sensing chamber with vacuum cleaner per unit's instructions. 1b. See unit's instructions for locations to avoid. Relocate as necessary. 1c. Replace detector.
2. <b>Detector's siren sounds.</b>	2a. Unit not receiving required power. 2b. Unit malfunctioning.	2a. Check for proper installation of battery. Try new battery. 2b. Replace detector.

# CONTACTING TECHNICAL SUPPORT

**PLEASE,**

**Before you call Technical Support, be sure you:**

- **READ THE INSTRUCTIONS!**
- **Check all wiring connections.**
- **Determine that the power supply and/or backup battery are supplying proper voltages.**
- **Verify your programming information where applicable.**
- **Note the proper model number of this product, and the version level (if known) along with any documentation that came with the product.**
- **Note your ADEMCO customer number and/or company name.**

**Having this information handy will make it easier for us to serve you quickly and effectively.**

You may contact Technical Support via Toll Free Fax. Please include your return fax number. You will receive a reply within 24 hours. You may also contact Technical Support via modem to ATLIS-BBS, Tech Support's Electronic Bulletin Board System. Replies are posted within 24 hours.

*East Coast Technical Support:* ..... 1-800-645-7492 (8 a.m.-6 p.m. E.S.T.)

*West Coast Technical Support:* ..... 1-800-458-9469 (8 a.m.-5 p.m. P.S.T.)

*Technical Support Fax Number:* ..... 1-800-447-5086

*ATLIS-BBS Electronic Bulletin Board System:* ..... 1-516-496-3980  
(1200 - 9600 Baud, 8 Data Bits, 1 Start/Stop Bit, No Parity)

*ATLIS-FAX FAXBACK Automated Fax Retrieval System:*..... 1-800-573-0153 or  
1-516-921-6704 / ext. 1667

*World Wide Web Address:* ..... [HTTP://WWW.ADEMCO.COM](http://WWW.ADEMCO.COM)

# REGULATORY AGENCY STATEMENTS

## UL NOTICE: This is a "Grade A" residential system.

### **FEDERAL COMMUNICATIONS COMMISSION (FCC) Part 15 STATEMENT**

This equipment has been tested to FCC requirements and has been found acceptable for use. The FCC requires the following statement for your information:

This equipment generates and uses radio frequency energy and if not installed and used properly, that is, in strict accordance with the manufacturer's instructions, may cause interference to radio and television reception. It has been type tested and found to comply with the limits for a Class B computing device in accordance with the specifications in Part 15 of FCC Rules, which are designed to provide reasonable protection against such interference in a residential installation. However, there is no guarantee that interference will not occur in a particular installation. If this equipment does cause interference to radio or television reception, which can be determined by turning the equipment off and on, the user is encouraged to try to correct the interference by one or more of the following measures:

- If using an indoor antenna, have a quality outdoor antenna installed.
- Reorient the receiving antenna until interference is reduced or eliminated.
- Move the radio or television receiver away from the receiver/control.
- Move the antenna leads away from any wire runs to the receiver/control.
- Plug the receiver/control into a different outlet so that it and the radio or television receiver are on different branch circuits.

If necessary, the user should consult the dealer or an experienced radio/television technician for additional suggestions. The user or installer may find the following booklet prepared by the Federal Communications Commission helpful: "Interference Handbook"

This booklet is available from the U.S. Government Printing Office, Washington, DC 20402.

*The user shall not make any changes or modifications to the equipment unless authorized by the Installation Instructions or User's Manual. Unauthorized changes or modifications could void the user's authority to operate the equipment.*

### **FEDERAL COMMUNICATIONS COMMISSION (FCC) Part 68 STATEMENT**

This equipment complies with Part 68 of the FCC rules. On the front cover of this equipment is a label that contains, among other information, the FCC registration number and ringer equivalence number (REN) for this equipment. If requested, this information must be provided to the telephone company.

This equipment uses the following jacks: An RJ31X is used to connect this equipment to the telephone network.

The REN is used to determine the quantity of devices which may be connected to the telephone line. Excessive RENs on the telephone line may result in the devices not ringing in response to an incoming call. In most, but not all areas, the sum of the RENs should not exceed five (5.0). To be certain of the number of devices that may be connected to the line, as determined by the total RENs, contact the telephone company to determine the maximum REN for the calling area.

If this equipment causes harm to the telephone network, the telephone company will notify you in advance that temporary discontinuance of service may be required. If advance notice is not practical, the telephone company will notify the customer as soon as possible. Also, you will be advised of your right to file a complaint with the FCC if you believe necessary.

The telephone company may make changes in its facilities, equipment, operations, or procedures that could affect the operation of the equipment. If this happens, the telephone company will provide advance notice in order for you to make the necessary modifications in order to maintain uninterrupted service.

If trouble is experienced with this equipment, please contact the manufacturer for repair and warranty information. If the trouble is causing harm to the telephone network, the telephone company may request you remove the equipment from the network until the problem is resolved.

There are no user serviceable components in this product, and all necessary repairs must be made by the manufacturer. Other repair methods may invalidate the FCC registration on this product.

This equipment cannot be used on telephone company-provided coin service. Connection to Party Line Service is subject to state tariffs.

This equipment is hearing-aid compatible.

When programming or making test calls to an emergency number, briefly explain to the dispatcher the reason for the call. Perform such activities in the off-peak hours; such as early morning or late evening.

# Section 24. SPECIFICATIONS & ACCESSORIES

## Specifications

### VISTA-20HWSE SECURITY CONTROL

**1. Physical:** 12-1/2" W x 14-1/2" H x 3" D (318mm x 368mm x 76mm)

**2. Electrical:**

VOLTAGE INPUT: 16.5VAC from plug-in 25VA transformer, Ademco No. 1321 (in U.S.A.)

RECHARGEABLE BACK-UP BATTERY: 12VDC, 4AH (Gel type).  
Charging Voltage: 13.8VDC.

ALARM SOUNDER: 12V, 2.0 Amp output can drive 12V BELLS or can drive one or two 702 (**series** connected) self-contained 20-watt sirens. Do **not** connect two 702s in parallel.

AUXILIARY POWER OUTPUT: 12VDC, 600mA max. Interrupts for 4-wire smoke detector reset.

**Note:** For UL installations, Alarm Sounder plus Auxiliary Power currents should not exceed 700mA total.

STANDBY TIME: (see Table in POWERING THE SYSTEM section)

FUSE: Battery (3A) No. 90-12

**3. Communication:**

FORMATS SUPPORTED:

**Ademco Express,**

10 characters/sec, DTMF (TouchTone) Data Tones, 1400/2300Hz ACK, 1400Hz KISSOFF.

**Ademco Contact ID Reporting,**

10 characters/sec., DTMF (TouchTone) Data Tones, 1400/2300Hz ACK, 1400Hz KISSOFF.

**Ademco Low Speed,** 10 pulses/sec, 1900Hz Data Tone, 1400Hz ACK/KISSOFF.

**Radionics/SESCOA,** 20 pulses/sec, 1800Hz Data Tone, 2300Hz ACK/KISSOFF. Can report 0-9, B-F

Line Seize: Double Pole

Ringer Equivalence: 0.7B

FCC Registration No.: AC 398U-68192-AL-E

**4. Maximum Zone Resistance:** Zones 1-8 = 300 ohms excluding EOLR

### 4127 REMOTE KEYPAD

**1. Physical:** 5-5/8" W x 4-11/16" H x 7/8" D (143mm x 119mm x 22mm)

**2. Electrical:** Voltage Input: 12VDC, Current Drain: 20mA

**3. Interface Wiring:** To control panel's keypad connection points.

RED: 12VDC input (+) aux pwr

GREEN: Data Out to Control

YELLOW: Data In from Control

BLACK: Ground

### 4137AD & 5137AD REMOTE KEYPADS

**1. Physical:** 8-2/5" W x 4-3/4" H x 1-1/10" D (213mm x 121mm x 28mm)

**2. Electrical:** Voltage Input: 12VDC,  
Current Drain: 60mA (4137AD)  
90mA(5137AD)

**3. Interface Wiring:**

RED: 12VDC input (+) aux pwr

BLUE: 18VDC input from optional No 1350 or 1360 Power Pack  
(not usable for UL installations)

GREEN: Data Out to Control

YELLOW: Data In from Control

BLACK: Ground (-) connection from optional No. 1350/1360 Power Pack.

- 6127 REMOTE KEYPAD**
- 1. Physical:** 5-3/4" W x 4-3/4" H x 1" D (146mm x 121mm x 26mm)
  - 2. Electrical:** Voltage Input: 12VDC; Current Drain: 20mA
  - 3. Interface Wiring:** Same as 4127.
- 6128 REMOTE KEYPAD**
- 1. Physical:** 5-3/4" W x 4-3/4" H x 1" D (146mm x 121mm x 26mm)
  - 2. Electrical:** Voltage Input: 12VDC; Current Drain: 30mA
  - 3. Interface Wiring:** Same as 4127.
- 6137 REMOTE KEYPAD**
- 1. Physical:** 6-1/4" W x 4-3/4" H x 1" D (159mm x 121mm x 26mm)
  - 2. Electrical:** Voltage Input: 12VDC; Current Drain: 85mA
  - 3. Interface Wiring:** Same as 4127.
- 6138 & 6139 REMOTE KEYPADS**
- 1. Physical:** 6-1/4" W x 4-3/4" H x 1" D (159mm x 121mm x 26mm)
  - 2. Electrical:** Voltage Input: 12VDC; Current Drain: 100mA
  - 3. Interface Wiring:** Same as 4127.
- 4219 WIRED EXPANSION MODULE**
- 1. Physical:** 6-1/2" W x 4-1/4" H x 1-1/4" D (169mm x 108mm x 32mm)
  - 2. Electrical:** Voltage Input: 12VDC; Current Drain: 35mA
  - 3. Interface Wiring:** Same as 4127.
  - 4. 8 EOLR Loops (A-H):** Loop A can be set for fast (10–15msec) response to an open.
- 4204 RELAY MODULE**
- 1. Physical:** 6-1/2" W x 4-1/4" H x 1-1/4" D (169mm x 108mm x 32mm)
  - 2. Electrical:** Voltage Input: 12VDC; Current Drain: 15mA (Relays off)  
180mA (Relays on)
  - 3. Interface Wiring:** Same as 4127
  - 4. Four Output Relays:** SPDT Contacts,  
Rating: 2A max at 28VDC/AC
- 4229 WIRED EXPANSION/RELAY MODULE**
- 1. Physical:** 6-1/2" W x 4-1/4" H x 1-1/4" D (169mm x 108mm x 32mm)
  - 2. Electrical:** Voltage Input: 12VDC; Current Drain: 35mA (Relays off)  
100mA (Relays on)
  - 3. Interface Wiring:** Same as 4127.
  - 4. 8 EOLR Loops (A-H):** Loop A can be set for fast (10–15msec) response to an open.
  - 5. Two Output Relays:** SPDT Contacts, Rating: 2A max at 28VDC/AC
- 4285 PHONE MODULE**
- 1. Physical:** 6-1/2" W x 4-1/4" H x 1-1/4" D (169mm x 108mm x 32mm)
  - 2. Electrical:** Voltage Input: 12VDC Current Drain: 160mA
  - 3. Device Address:** Permanently set to address 4.
  - 4. Interface Wiring:** See 4285 PHONE MODULE section.
  - 5. Telephone Line Connections:** See 4285 PHONE MODULE section.

Accessories (Compatible Devices)

	<b>No. 1321</b>	16.5VAC, 25VA Plug-In Transformer	
	<b>No. 4300</b>	Powerline Carrier device Interface AC Transformer	
Sounders	<b>Ademco AB-12M 10" Motorized Bell &amp; Box</b>	Motor bell & box. UL Grade A. 100 mA current draw.	
	<b>Ademco 1011BE12M 10" Motorized Bell &amp; Box</b>	Motor bell & box. UL Listed. 100 mA current draw.	
	<b>Ademco 702 Outdoor Siren</b>	Self-contained 6–12 volt siren (driver built-in) and weatherproof for outdoor use. Can be wired for either a steady or warble sound.	
	<b>Ademco 719 2-Channel Siren</b>	Two-channel, self-contained 6–12-volt siren (driver built in). 109dB @ 10 feet. 550mA current draw.	
	<b>Ademco 747 Indoor Siren</b>	Self-contained 12 volt siren (driver built-in) for indoor wall mount. 747F available for flush mounting.	
	<b>Ademco 747UL Indoor Siren</b>	Self-contained siren (driver built-in) for indoor wall mount. UL Listed.	
	<b>Ademco 744 Siren Driver</b>	6 jumper-selected sound outputs. Rated at 119dB with use of an 8-ohm 30 watt speaker.	
	<b>Ademco 745X3 Voice Siren Driver</b>	Voice siren driver with English, Spanish and French voice messages. Separate messages for Fire and Burglary. Use with 8-ohm speaker. UL Listed.	
		<b>Ademco 705–820, 5-inch Round Speaker</b>	15-watt, 8-ohm speaker.
		<b>Ademco 713 Speaker</b>	40-watt, 8-ohm, indoor/outdoor speaker.
	<b>System Sensor PA400B (beige)/PA400R (red) Indoor Piezo Sounder</b>	Indoor piezo sounder (red or beige), rated at 90 dB @ 10 feet.	
Compatible 2-Wire Smoke Detectors	<b>System Sensor</b>		
	<b>2300T</b>	Photoelectric w/heat sensor, direct wire	
	<b>2400</b>	Photoelectric, direct wire	
	<b>2400TH</b>	Photoelectric w/heat sensor, direct wire	
	<b>2451</b>	Photoelectric w/B401B base	
	<b>2451TH</b>	Photoelectric w/heat sensor & B401Bbase	
	<b>1400</b>	Ionization, direct wire	
	<b>1451</b>	Ionization w/B401B base	
	<b>2451</b>	Photoelectric duct detector w/DH400 base	
	<b>1451DH</b>	Ionization duct detect. w/DH400 base	
Compatible 4-Wire Smoke/Combustion Detectors	<b>System Sensor</b>		
	<b>1412</b>	4-wire ionization products of combustion detector	
	<b>2412</b>	4-wire photoelectric smoke detector	
	<b>2412TH</b>	4-wire photoelectric smoke detector w/135° F (57° C) heat detector	
	<b>A77–716B</b>	EOL relay module (supervisory module for wired 4-wire fire zone).	
	<b>2112/24T</b>	Low-profile 4-wire photoelectric smoke detector w/135° F (57° C) heat detector	

# INDEX

1-minute delay .....	34	Ademco 747 .....	29
1011BE12M .....	29	Ademco AB-12M 10" Motorized Bell & Box .....	29
1321 AC transformer .....	8, 9, 11, 23, 34	Ademco Contact ID .....	9, 64
1400 .....	76	Ademco Express .....	9, 74
1412 .....	76	Ademco Low Speed .....	9, 74
1451 .....	76	ALARM BELL TIMEOUT .....	41
1451DH .....	76	Alarm Output .....	9, 30, 35
15-SECOND DIALER DELAY (BURGLARY) .....	44	ALARM RESTORE REPORT CODE, 1st DIGIT .....	46
2-digit phone code .....	28	alarm sounders .....	30
2112/24T .....	76	Alpha descriptor .....	58
2300T .....	76	Alpha keypad .....	37
24-hour .....	39	Alpha Keypads .....	7
24-hour Audible Alarm .....	39	Alpha Vocabulary .....	56, 57
24-hour Silent Alarm .....	39	answering machine .....	48
2400 .....	76	ARM AWAY/STAY REPORT CODE .....	46
2400TH .....	76	Arming Away .....	67
2412 .....	18, 76	Arming Instant .....	67
2412TH .....	18, 76	Arming Maximum .....	67
2451 .....	76	ARMING MODES .....	67
2451TH .....	76	Arming Stay .....	67
3+1 and 4+1 Expanded Formats .....	64	ATLIS-BBS .....	72
3+1 and 4+1 Standard Formats .....	64	AUDIBLE EXIT WARNING .....	42
3+1 or 4+1 Standard Format .....	45	Audio Alarm Verification .....	8, 32
3-digit number .....	56, 57	Audio Alarm Verification (AAV) .....	25
4+2 Format .....	64	Auxiliary Output .....	35
4-wire smoke detectors .....	16	Auxiliary Power Output .....	9
4127 .....	13, 74		
4127* .....	7	Baby-sitter Code .....	8
4137AD .....	7, 13, 14, 74	Back-Up Battery .....	9, 12, 30, 34
4142TR cable .....	12, 24	Basic Hardwired Zones .....	7
4204 .....	8, 22, 32, 37, 53, 68, 75	battery connector cable .....	35
4219 .....	7, 20, 21, 22, 75	Battery Size .....	34
4229 .....	7, 8, 20, 21, 22, 32, 37, 53, 68, 75	battery standby formula .....	35
4285 .....	11, 25, 26, 27, 28, 32, 59, 75	bells .....	30
4285 Phone Module .....	8, 56	BYPASS REPORT CODE .....	46
4300 transformer .....	8, 11, 22, 23	BYPASS RESTORE REPORT CODE .....	46
487-12 .....	14	Bypassing Zones .....	67
488-12 .....	14		
5137AD .....	7, 9, 13, 14, 36, 74	cabinet lock .....	10
5137TRK .....	14	Caller ID unit .....	26, 27
6127 .....	13, 75	CANCEL REPORT CODE .....	46
6127* .....	7	central station .....	45
6128 .....	13, 14, 75	CHARACTER (ASCII) CHART .....	60
6128. ....	7	CHARACTER CHART .....	56
6137 .....	7, 13, 14, 75	CHARACTER LIST .....	59
6138 .....	7, 13, 14, 75	Charging Voltage .....	74
6139 .....	7, 9, 13, 14, 36, 75	Chime Mode .....	67
6139TRK .....	14	Common Zone .....	7, 55
702 .....	76	Communication .....	74
705-820 .....	76	communication failure .....	69
713 .....	76	Communication Formats Supported .....	9
719 .....	76	COMPATIBLE 2-WIRE SMOKE DETECTORS .....	17, 76
744 .....	76	Compatible Glass Break Detectors .....	18
745X3 .....	76	CONFIRMATION OF ARMING DING .....	42
747 .....	76	Contact ID .....	31, 45, 65
747UL .....	76	CONTACT ID EVENT CODES .....	65
7720 PLUS or 7820 .....	31	Contact ID Reporting .....	74
7720PLUS or 7820 .....	9	control cabinet .....	10
A77-716B .....	18, 76	Control's Circuit Board .....	10
		Custom Words .....	59, 60
AC LOSS REPORT CODE .....	46		
AC Power Supply .....	9	Default Descriptor .....	57
AC RESTORE REPORT CODE .....	46	device address .....	20
AC Transformer .....	11	DIALER PROGRAMMING .....	42
addressable keypads .....	13, 14, 25	DIP switch .....	20, 22
Ademco 744 .....	29		
Ademco 745X3 .....	29		

Disarmed, Not Ready .....	67	No. A77-716B .....	17
Disarming .....	67	NUMBER OF REPORTS IN ARMED PERIOD .....	47
DOWNLOAD INFORMATION .....	48	Off-Premises Phone .....	28
DOWNLOAD PHONE NUMBER .....	48	On-Premises Phone .....	28
Duress Code .....	8	OPEN REPORT CODE .....	46
Eagle 1241 .....	32	Optima 24 Plus FAX96 Modem .....	61
Earth Ground .....	12, 34	OPTION SELECTION .....	47
Entering .i.Program Mode .....	36	Output Devices .....	51
entry delay .....	1	Output Relays .....	8, 53
Entry/Exit Burglary .....	1, 2	OUTPUT TO LONG RANGE RADIO .....	41
EOL resistor .....	16, 17, 19, 21	PA400B .....	76
EOL resistors .....	15	PA400R .....	29
EOLR .....	20	PABX ACCESS CODE .....	42
EVENT LOG 80% FULL REPORT CODE .....	47	Panic Keys .....	68
Event Logging .....	9, 47	Partition Default .....	49
Exit Error Alarm .....	68	Partitions .....	7
EXIT ERROR REPORT CODE .....	45	Perimeter Burglary .....	38
Expanded or 4+2 Format .....	45	PERIODIC TEST REPORT .....	44
Factory Defaults .....	37	Phone Line .....	11
FCC .....	73	PHONE LINE MONITOR ENABLE .....	47
Fire alarm sounding .....	17	Phone Module .....	11, 25, 26, 27, 48, 68
FIRE SOUNDER TIMEOUT .....	41	PHONE MODULE ACCESS CODE .....	40
Fixed-Word Keypads .....	7	PHONE SYSTEM SELECT .....	43
Forced (Quick) Bypass .....	67	Power Failure .....	69
FORCED BYPASS .....	36	POWER" LED .....	34
FORCED BYPASS FUNCTION .....	40	POWER UP IN PREVIOUS STATE .....	42
formats .....	63	Powerline Carrier device .....	54
FUSE .....	74	POWERLINE CARRIER DEVICE HOUSE ID .....	40
handshake .....	63	Powerline Carrier devices .....	9, 22, 23, 53, 68
hard-wired zones .....	16	Powerline Carrier Devices (X-10 type) .....	8
HAYES modem specified by Ademco .....	9	PRIMARY PHONE No. ....	42
HAYES Modem .....	61	PRIMARY SUBS ACCOUNT. No. ....	43
IBM compatible Personal Computer (PC) .....	61	Program Upload or Download Time .....	62
IBM personal computer .....	36	Programming Information .....	36
Ideal Model 61-035 .....	12, 34	PULSE dialing .....	25
IEI 735L series detectors .....	18	QUICK ARM .....	67
INITIALIZE DOWNLOAD ID AND SUBSCRIBER ACCT. No. FOR DOWNLOADING .....	48	QUICK ARM ENABLE .....	36, 40
Input Device types .....	50	Radionics/SESCOA .....	74
INSTALLER CODE .....	36, 40	"READY" LED .....	34
Interior w/Delay .....	39	Relay outputs .....	22
Interior, Follower .....	38	Relay Programming .....	37
Keypad Connections .....	14	Relays .....	22
Keypad Panic Keys .....	8	Remote Keypads .....	7
keypads .....	13, 14	REMOTE PROGRAMMING .....	61
kissoff .....	63	Report code .....	45, 49
line seizure wiring .....	27	Report Code Formats .....	63
Lock .....	10	report codes .....	45
Long Range Radio .....	9, 31	REPORT FORMAT .....	43
LOW BAT REPORT CODE .....	46	Response Time .....	49
LOW BAT RESTORE REPORT CODE .....	46	RESTORE .....	46
low battery message .....	35, 71	RING DETECTION COUNT FOR DOWNLOADING .....	48
LRR communication failure .....	69	RJ31X jack .....	11, 26, 27
Magnets .....	71	SECONDARY PHONE No. ....	42
main PC board .....	10	SECONDARY SUBS ACCOUNT. No. ....	43
Master code .....	66	Secondary User Codes .....	66
modem .....	36	Security Codes .....	66
monitored telephone line .....	69	Sescoa/Radionics .....	9
No Alarm Response .....	39	SESCOA/RADIONICS SELECT .....	44
No. 4300 .....	76	SET ALL PROGRAM FIELDS TO DEFAULT VALUES .....	48
No. 467 (12V, 4AH) battery .....	34	Silent Burglary .....	39
		Silent Panic .....	68
		SINGLE ALARM SOUNDING PER ZONE .....	41
		sirens .....	30

SMARTMODEM 1200 .....	61
Sounders .....	76
SPLIT/DUAL REPORTING .....	43
Supervised Fire .....	39
Supplementary Power Supply .....	14
SYSTEM COMMUNICATION .....	63
SYSTEM OPERATION .....	53
System Sensor PA400B .....	29
system status and restore REPORT CODES .....	45
SYSTEM STATUS REPORT CODES .....	45
tamper protection .....	20
TECHNICAL SUPPORT CONTACT .....	72
Telco line .....	27
Telephone Line Monitoring .....	9
Test Mode .....	70
TEST REPORT CODE .....	46
TEST REPORT OFFSET .....	44
TEST RESTORE REPORT CODE .....	46
Touch-tone .....	25
TouchTone phone .....	28
Trouble by Day/ .....	38
trouble condition .....	69
TROUBLE REPORT CODE .....	46
TROUBLE RESTORE REPORT CODE .....	46
UL .....	12, 14, 29, 31, 35, 73, 74
V-LINK® Downloading Software Diskette .....	62
V-LINK® Software .....	61
VOCABULARY LIST .....	60
WIRED ZONE EXPANSION .....	36, 37, 40
Wiring 2-Wire Smoke Detector .....	16
wiring length/gauge chart .....	13
Wiring Run Chart .....	13
word string .....	59
WORKSHEET .....	35
Zone Descriptors .....	9
Zone Descriptors .....	60
Zone Expansion .....	20
Zone List .....	37
Zone Programming .....	37
Zone Type Default .....	49
Zone types .....	38, 53

**- NOTES -**

**- NOTES -**

**WARNING**  
**THE LIMITATIONS OF THIS ALARM SYSTEM**

While this System is an advanced design security system, it does not offer guaranteed protection against burglary, fire or other emergency. Any alarm system, whether commercial or residential, is subject to compromise or failure to warn for a variety of reasons. For example:

- Intrusion detectors (e.g., passive infrared detectors), smoke detectors, and many other sensing devices will not work without power. Battery-operated devices will not work without batteries, with dead batteries, or if the batteries are not put in properly. Devices powered solely by AC will not work if their AC power supply is cut off for any reason, however briefly.
- Signals sent by wireless transmitters may be blocked or reflected by metal before they reach the alarm receiver. Even if the signal path has been recently checked during a weekly test, blockage can occur if a metal object is moved into the path.
- A user may not be able to reach a panic or emergency button quickly enough.
- While smoke detectors have played a key role in reducing residential fire deaths in the United States, they may not activate or provide early warning for a variety of reasons in as many as 35% of all fires, according to data published by the Federal Emergency Management Agency. Some of the reasons smoke detectors used in conjunction with this System may not work are as follows. Smoke detectors may have been improperly installed and positioned. Smoke detectors may not sense fires that start where smoke cannot reach the detectors, such as in chimneys, in walls, or roofs, or on the other side of closed doors. Smoke detectors also may not sense a fire on another level of a residence or building. A second floor detector, for example, may not sense a first floor or basement fire. Finally, smoke detectors have sensing limitations. No smoke detector can sense every kind of fire every time. In general, detectors may not always warn about fires caused by carelessness and safety hazards like smoking in bed, violent explosions, escaping gas, improper storage of flammable materials, overloaded electrical circuits, children playing with matches, or arson. Depending on the nature of the fire and/or location of the smoke detectors, the detector, even if it operates as anticipated, may not provide sufficient warning to allow all occupants to escape in time to prevent injury or death.
- Passive Infrared Motion Detectors can only detect intrusion within the designed ranges as diagrammed in their installation manual. Passive Infrared Detectors do not provide volumetric area protection. They do create multiple beams of protection, and intrusion can only be detected in unobstructed areas covered by those beams. They cannot detect motion or intrusion that takes place behind walls, ceilings, floors, closed doors, glass partitions, glass doors, or windows. Mechanical tampering, masking, painting or spraying of any material on the mirrors, windows or any part of the optical system can reduce their detection ability. Passive Infrared Detectors sense changes in temperature; however, as the ambient temperature of the protected area approaches the temperature range of 90° to 105°F (32° to 40°C), the detection performance can decrease.
- Alarm warning devices such as sirens, bells or horns may not alert people or wake up sleepers if they are located on the other side of closed or partly open doors. If warning devices are located on a different level of the residence from the bedrooms, then they are less likely to waken or alert people inside the bedrooms. Even persons who are awake may not hear the warning if the alarm is muffled by noise from a stereo, radio, air conditioner or other appliance, or by passing traffic. Finally, alarm warning devices, however loud, may not warn hearing-impaired people.
- Telephone lines needed to transmit alarm signals from a premises to a central monitoring station may be out of service or temporarily out of service. Telephone lines are also subject to compromise by sophisticated intruders.
- Even if the system responds to the emergency as intended, however, occupants may have insufficient time to protect themselves from the emergency situation. In the case of a monitored alarm system, authorities may not respond appropriately.
- This equipment, like other electrical devices, is subject to component failure. Even though this equipment is designed to last as long as 20 years, the electronic components could fail at any time.

The most common cause of an alarm system not functioning when an intrusion or fire occurs is inadequate maintenance. This alarm system should be tested weekly to make sure all sensors and transmitters are working properly. The security keypad (and remote keypad) should be tested as well.

Wireless transmitters (used in some systems) are designed to provide long battery life under normal operating conditions. Longevity of batteries may be as much as 4 to 7 years, depending on the environment, usage, and the specific wireless device being used. External factors such as humidity, high or low temperatures, as well as large swings in temperature, may all reduce the actual battery life in a given installation. This wireless system, however, can identify a true low battery situation, thus allowing time to arrange a change of battery to maintain protection for that given point within the system.

Installing an alarm system may make the owner eligible for a lower insurance rate, but an alarm system is not a substitute for insurance. Homeowners, property owners and renters should continue to act prudently in protecting themselves and continue to insure their lives and property.

We continue to develop new and improved protection devices. Users of alarm systems owe it to themselves and their loved ones to learn about these developments.

Figure 22. VISTA-20HWS<sup>SE</sup> SUMMARY OF CONNECTIONS

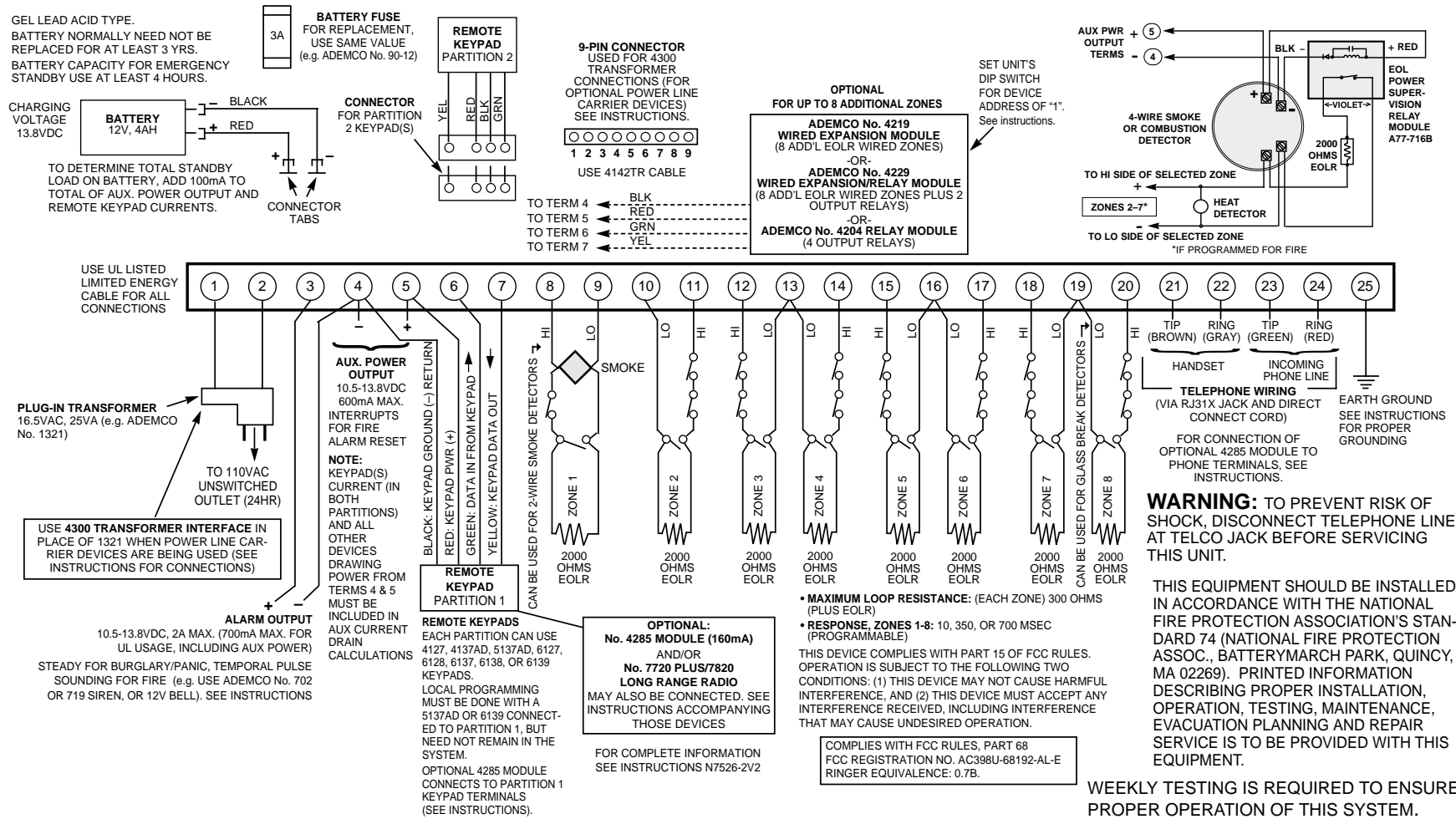

## **ADEMCO LIMITED WARRANTY**

Alarm Device Manufacturing Company, a Division of Pittway Corporation, and its divisions, subsidiaries and affiliates ("Seller"), 165 Eileen Way, Syosset, New York 11791, warrants its products to be in conformance with its own plans and specifications and to be free from defects in materials and workmanship under normal use and service for 24 months from the date stamp control on the product or, for products not having an Ademco date stamp, for 12 months from date of original purchase unless the installation instructions or catalog sets forth a shorter period, in which case the shorter period shall apply. Seller's obligation shall be limited to repairing or replacing, at its option, free of charge for materials or labor, any product which is proved not in compliance with Seller's specifications or proves defective in materials or workmanship under normal use and service. Seller shall have no obligation under this Limited Warranty or otherwise if the product is altered or improperly repaired or serviced by anyone other than Ademco factory service. For warranty service, return product transportation prepaid, to Ademco Factory Service, 165 Eileen Way, Syosset, New York 11791.

THERE ARE NO WARRANTIES, EXPRESS OR IMPLIED, OF MERCHANTABILITY, OR FITNESS FOR A PARTICULAR PURPOSE OR OTHERWISE, WHICH EXTEND BEYOND THE DESCRIPTION ON THE FACE HEREOF. IN NO CASE SHALL SELLER BE LIABLE TO ANYONE FOR ANY CONSEQUENTIAL OR INCIDENTAL DAMAGES FOR BREACH OF THIS OR ANY OTHER WARRANTY, EXPRESS OR IMPLIED, OR UPON ANY OTHER BASIS OF LIABILITY WHATSOEVER, EVEN IF THE LOSS OR DAMAGE IS CAUSED BY THE SELLER'S OWN NEGLIGENCE OR FAULT.

Seller does not represent that the products it sells may not be compromised or circumvented; that the products will prevent any personal injury or property loss by burglary, robbery, fire or otherwise; or that the products will in all cases provide adequate warning or protection. Customer understands that a properly installed and maintained alarm may only reduce the risk of a burglary, robbery, fire or other events occurring without providing an alarm, but it is not insurance or a guarantee that such will not occur or that there will be no personal injury or property loss as a result. CONSEQUENTLY, SELLER SHALL HAVE NO LIABILITY FOR ANY PERSONAL INJURY, PROPERTY DAMAGE OR OTHER LOSS BASED ON A CLAIM THE PRODUCT FAILED TO GIVE WARNING. HOWEVER, IF SELLER IS HELD LIABLE, WHETHER DIRECTLY OR INDIRECTLY, FOR ANY LOSS OR DAMAGE ARISING UNDER THIS LIMITED WARRANTY OR OTHERWISE, REGARDLESS OF CAUSE OR ORIGIN, SELLER'S MAXIMUM LIABILITY SHALL NOT IN ANY CASE EXCEED THE PURCHASE PRICE OF THE PRODUCT, WHICH SHALL BE THE COMPLETE AND EXCLUSIVE REMEDY AGAINST SELLER. This warranty replaces any previous warranties and is the only warranty made by Seller on this product. No increase or alteration, written or verbal, of the obligations of this Limited Warranty is authorized.

**® ADEMCO**

ALARM DEVICE MANUFACTURING CO.  
A DIVISION OF PITTMAY CORPORATION

165 Eileen Way, Syosset, New York 11791

Copyright © 1997 PITTMAY CORPORATION

